

Tabla 26 Cerámicas comunes usados en materiales compuestos de matriz cerámica

Matrix Material	Density (g/cm ³)	Use Temperature (°C)
Alumina, Al ₂ O ₃	4.0	~1000
Glass ceramics	2.7	900
Si ₃ N ₄	3.1	~1300
SiC	3.2	~1300

Capítulo 9

Corrosión

1.9. Corrosión química y electroquímica

1.9.1. Serie de potenciales de reducción estándar

	Reacciones del electrodo	Potencial de electrodo estándar V° (V)
<p style="text-align: center;">↑</p> <p>Más Inerte (Catódico)</p>	Au ³⁺ + 3e ⁻ → Au	+1,420
	O ₂ + 4H ⁺ + 4e ⁻ → 2H ₂ O	+1,229
	Pt ²⁺ + 2e ⁻ → Pt	~+1,2
	Ag ⁺ + e ⁻ → Ag	+0,800
	Fe ³⁺ + e ⁻ → Fe ²⁺	+0,771
	O ₂ + 2H ₂ O + 4e ⁻ → 4(OH ⁻)	+0,401
	Cu ²⁺ + 2e ⁻ → Cu	+0,340
	2H ⁺ + 2e ⁻ → H ₂	0
	Pb ²⁺ + 2e ⁻ → Pb	-0,126
	Sn ²⁺ + 2e ⁻ → Sn	-0,136
<p>Más Activo (Anódico)</p> <p style="text-align: center;">↓</p>	Ni ²⁺ + 2e ⁻ → Ni	-0,250
	Co ²⁺ + 2e ⁻ → Co	-0,277
	Cd ²⁺ + 2e ⁻ → Cd	-0,403
	Fe ²⁺ + 2e ⁻ → Fe	-0,440
	Cr ³⁺ + 3e ⁻ → Cr	-0,744
	Zn ²⁺ + 2e ⁻ → Zn	-0,763
	Al ³⁺ + 3e ⁻ → Al	-1,662
	Mg ²⁺ + 2e ⁻ → Mg	-2,363
	Na ⁺ + e ⁻ → Na	-2,714
	K ⁺ + e ⁻ → K	-2,294

Tabla 27 Serie Galvánica en presencia de agua de mar

	Platino
	Oro
	Grafito
	Titanio
	Plata
↑ Más inerte (catódico)	Acero inoxidable 316 (pasivo)
	Acero inoxidable 304 (pasivo)
	Inconel (80Ni-13Cr-7Fe) (pasivo)
	Níquel (pasivo)
	Monel (70Ni-30Cu)
	Aleaciones cobre-níquel
	Bronce (Cu-Sn)
	Cobre
	Latón (Cu-Zn)
	Inconel (activo)
Níquel (activo)	
↓ Más activo (anódico)	Estaño
	Plomo
	Acero inoxidable 316 (activo)
	Acero inoxidable 304 (activo)
	Fundición
	Hierro y acero
	Aleaciones de aluminio
	Cadmio
	Aluminio comercialmente puro
	Zinc
Magnesio y aleaciones de magnesio	

1.9.2. Diagramas de Pourbaix

1.9.2.1. Construcción del diagrama de Pourbaix del hierro



Tabla 28 Reacciones consideradas en el sistema significantes en el proceso de corrosión



Information needed: $E^{\ominus} = -0.440$ V SHE.

Apply the Nernst Eqn: $E = -0.440 - \frac{0.0591}{2} \cdot \log \frac{1}{a_{Fe^{2+}}}$
 $= -0.440 + 0.0295 \log(a_{Fe^{2+}})$

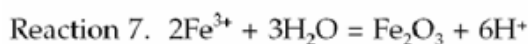
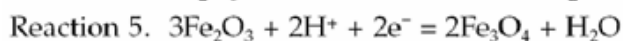
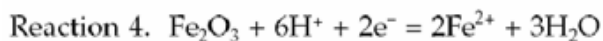
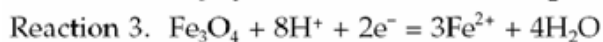
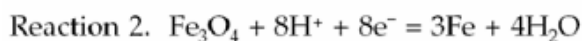
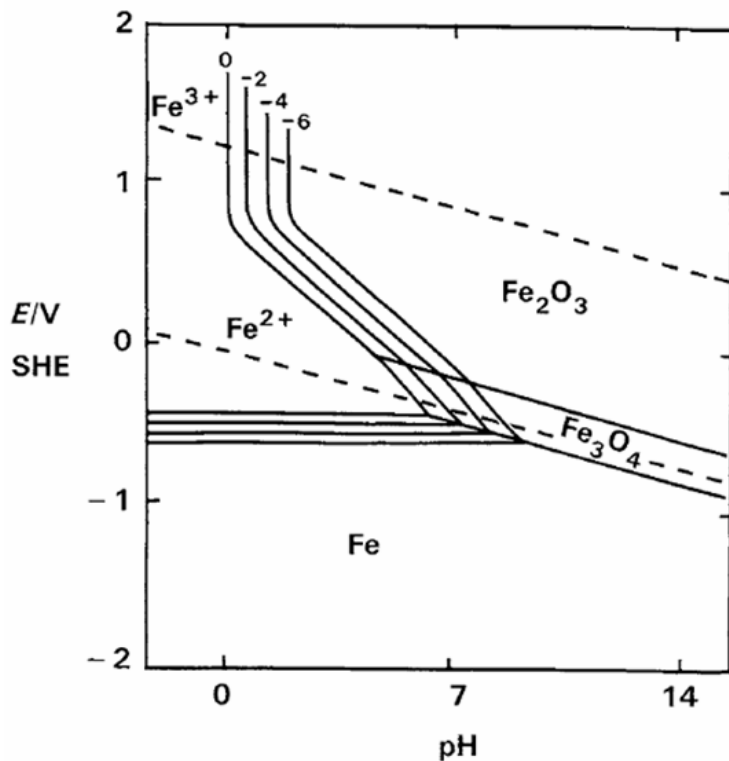
Figura 131 Diagrama de Pourbaix del Sistema Fe – H2O

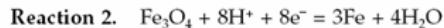

Information needed: $E^{\ominus} = -0.085$ V SHE.

Apply the Nernst Eqn: $E = -0.085 - \frac{0.0591}{8} \cdot \log \frac{1}{(a_{H^+})^8}$
 $= -0.085 - 0.0591$ pH



Information needed: $E^{\ominus} = +0.221$ V SHE.

Apply Nernst Eqn: $E = +0.221 - \frac{0.0591}{2} \cdot \log \frac{1}{(a_{H^+})^2}$
 $= 0.221 - 0.0591$ pH



Information needed: $E^{\ominus} = +0.980$ V SHE.

Apply the Nernst Eqn: $E = +0.980 - \frac{0.0591}{2} \cdot \log \frac{(a_{Fe^{2+}})^3}{(a_{H^+})^8}$
 $= 0.980 - 0.2364$ pH $- 0.0886 \log(a_{Fe^{2+}})^3$



Information needed: $E^{\ominus} = +0.771$ V SHE.

Apply the Nernst Eqn: $E = +0.771 - \frac{0.0591}{1} \cdot \log \frac{(a_{Fe^{2+}})}{(a_{Fe^{3+}})}$
 $= 0.771 + 0.0591 \log(a_{Fe^{3+}}) - 0.0591 \log(a_{Fe^{2+}})$



Information needed: $E^{\ominus} = +0.728$ V SHE.

Apply the Nernst Eqn: $E = +0.728 - \frac{0.0591}{2} \cdot \log \frac{(a_{Fe^{2+}})^2}{(a_{H^+})^6}$
 $= 0.728 - 0.1773$ pH $- 0.0591 \log(a_{Fe^{2+}})$

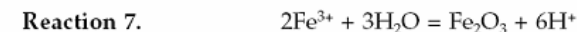

Information needed: $(a_{H^+})^6 / (a_{Fe^{3+}})^2 = 10^2$

Taking logarithms: $6 \log(a_{H^+}) - 2 \log(a_{Fe^{3+}}) = 2$

Hence, rearranging: $pH = \{- \log(a_{Fe^{3+}}) - 1\} / 3$



Figura 132 Izq. Diagrama de Pourbaix del Sistema Fe – H₂O a 25 C. $a_{Fe^{2+}} = a_{Fe^{3+}} = 1$. Las líneas A y B representan el dominio de estabilidad del agua. Arriba: velocidad de corrosión vs. pH en el proceso de corrosión del Fe. Der. Regiones en el diagrama donde se produce corrosión, pasividad e inmunidad del hierro. Abajo: Posibles reacciones que se pueden producir.

- | | |
|---|--|
| 1. $2 e^- + 2H^+ = 1H_2$ | 13. $1Fe^{2+} + 1H_2O = 1FeOH^+ + 1H^+$ |
| 2. $4 e^- + 1O_2 + 4H^+ = 2H_2O$ | 14. $1FeOH^+ + 1H_2O = 1Fe(OH)_{2(sln)} + 1H^+$ |
| 3. $2 e^- + 1Fe(OH)_2 + 2H^+ = 1Fe + 2H_2O$ | 15. $1Fe(OH)_{2(sln)} + 1H_2O = 1Fe(OH)_3^- + 1H^+$ |
| 4. $2 e^- + 1Fe^{2+} = 1Fe$ | 16. $1Fe^{3+} + 1H_2O = 1FeOH^{2+} + 1H^+$ |
| 5. $2 e^- + 1Fe(OH)_3^- + 3H^+ = 1Fe + 3H_2O$ | 17. $1FeOH^{2+} + 1H_2O = 1Fe(OH)_2^+ + 1H^+$ |
| 6. $1 e^- + 1Fe(OH)_3 + 1H^+ = 1Fe(OH)_2 + 1H_2O$ | 18. $1Fe(OH)_2^+ + 1H_2O = 1Fe(OH)_{3(sln)} + 1H^+$ |
| 7. $1 e^- + 1Fe(OH)_3 + 3H^+ = 1Fe^{2+} + 3H_2O$ | 19. $1 e^- + 1FeOH^{2+} + 1H^+ = 1Fe^{2+} + 1H_2O$ |
| 8. $1Fe(OH)_3^- + 1H^+ = 1Fe(OH)_2 + 1H_2O$ | 20. $1 e^- + 1Fe(OH)_2^+ + 2H^+ = 1Fe^{2+} + 2H_2O$ |
| 9. $1 e^- + 1Fe(OH)_3 = 1Fe(OH)_3^-$ | 21. $1 e^- + 1Fe(OH)_{3(sln)} + 1H^+ = 1Fe(OH)_{2(sln)} + 1H_2O$ |
| 10. $1Fe^{3+} + 3H_2O = 1Fe(OH)_3 + 3H^+$ | 22. $1 e^- + 1Fe(OH)_{3(sln)} + 2H^+ = 1FeOH^+ + 2H_2O$ |
| 11. $1Fe^{2+} + 2H_2O = 1Fe(OH)_2 + 2H^+$ | 23. $1 e^- + 1Fe(OH)_{3(sln)} + 3H^+ = 1Fe^{2+} + 3H_2O$ |
| 12. $1 e^- + 1Fe^{3+} = 1Fe^{2+}$ | |



Figura 133 Diagramas de Pourbaix de los sistemas Cu, Zn, Ni, Al y Sn – H₂O a 25°C. La actividad de los iones metálicos es igual a 10⁻⁶. El dominio de estabilidad del agua se muestra en líneas punteadas.

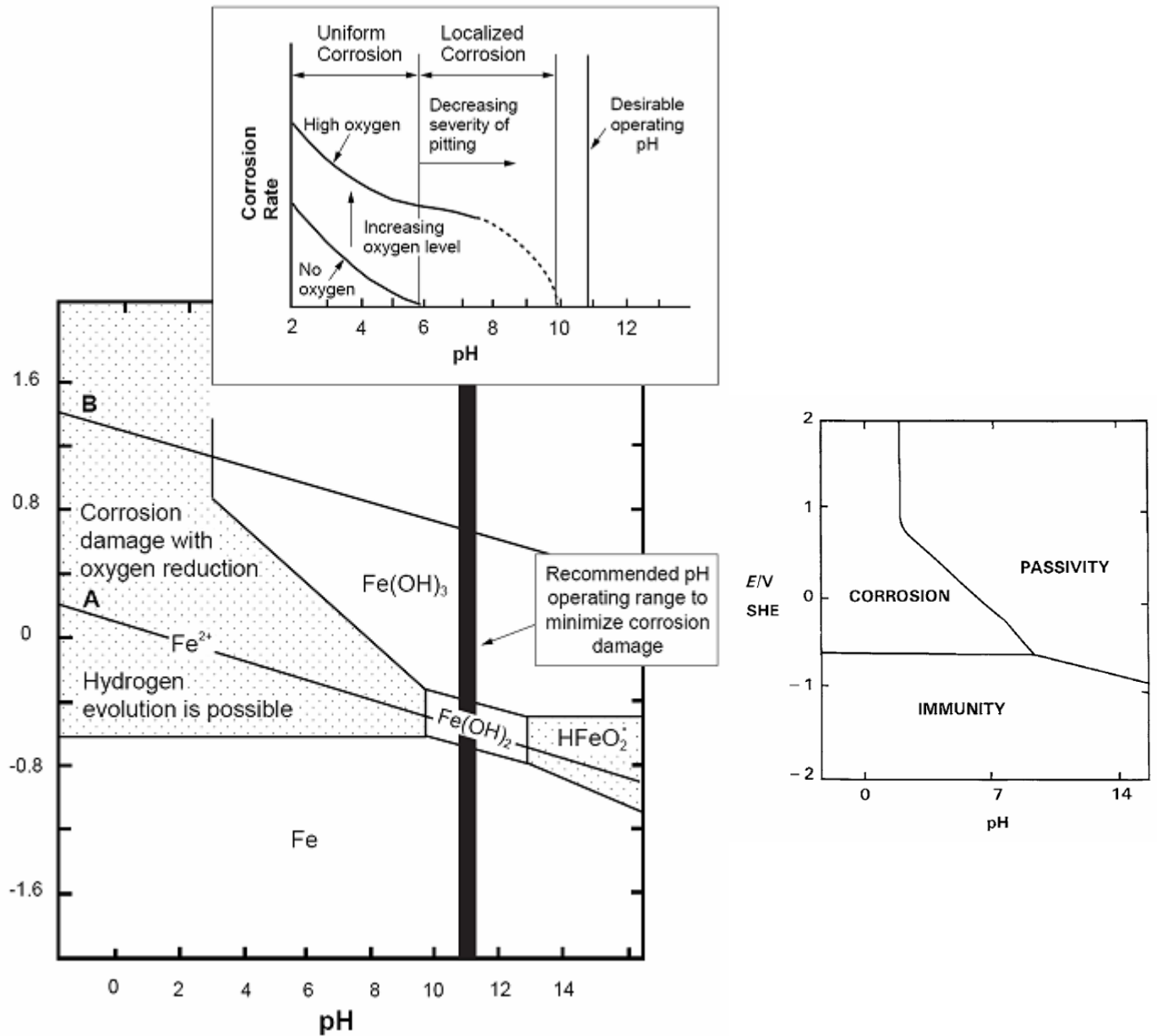

1.9.3. Pasivación de metales

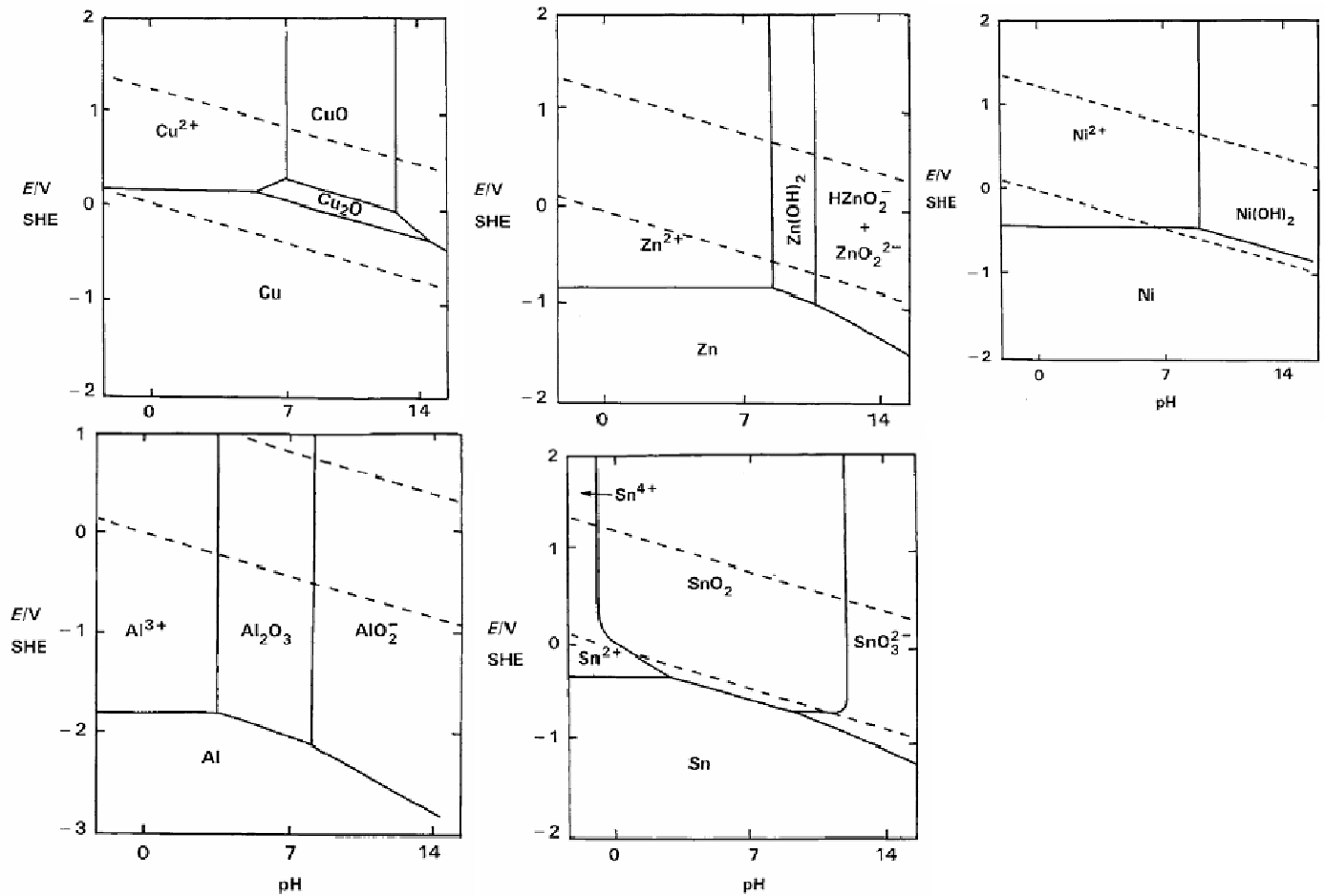
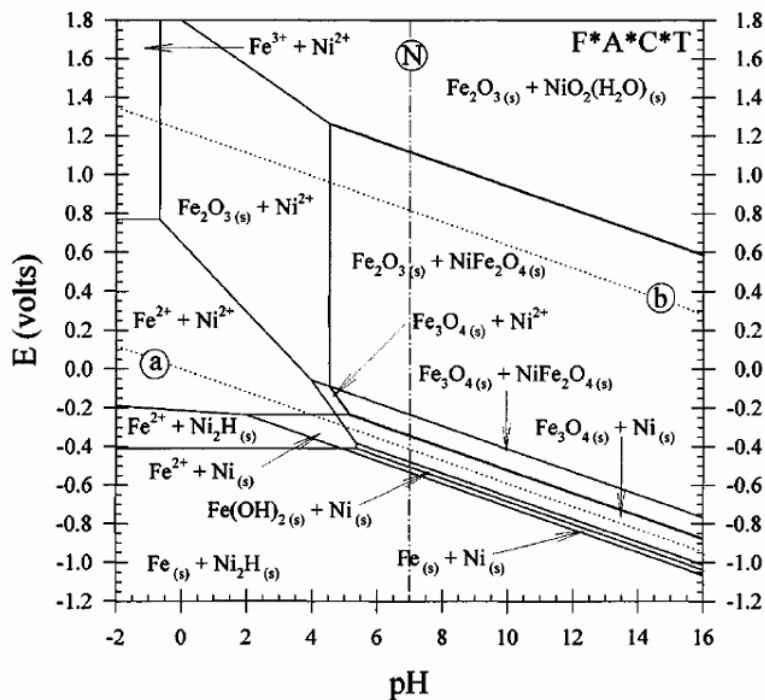

Figura 135 Izq. La densidad de corriente es la corriente por unidad de área de espécimen en amp/mm². Der. Curva de polarización esquemática para un metal que muestra la transición de activo a pasivo.



Figura 136 Existen diferentes compuestos que se pueden formar de acuerdo al metal que es sometido al proceso de corrosión (der.). Su deterioro se puede disminuir utilizando compuestos más nobles como los mostrados en la curva de polarización (izq.).

1.9.4. Tipos de corrosión

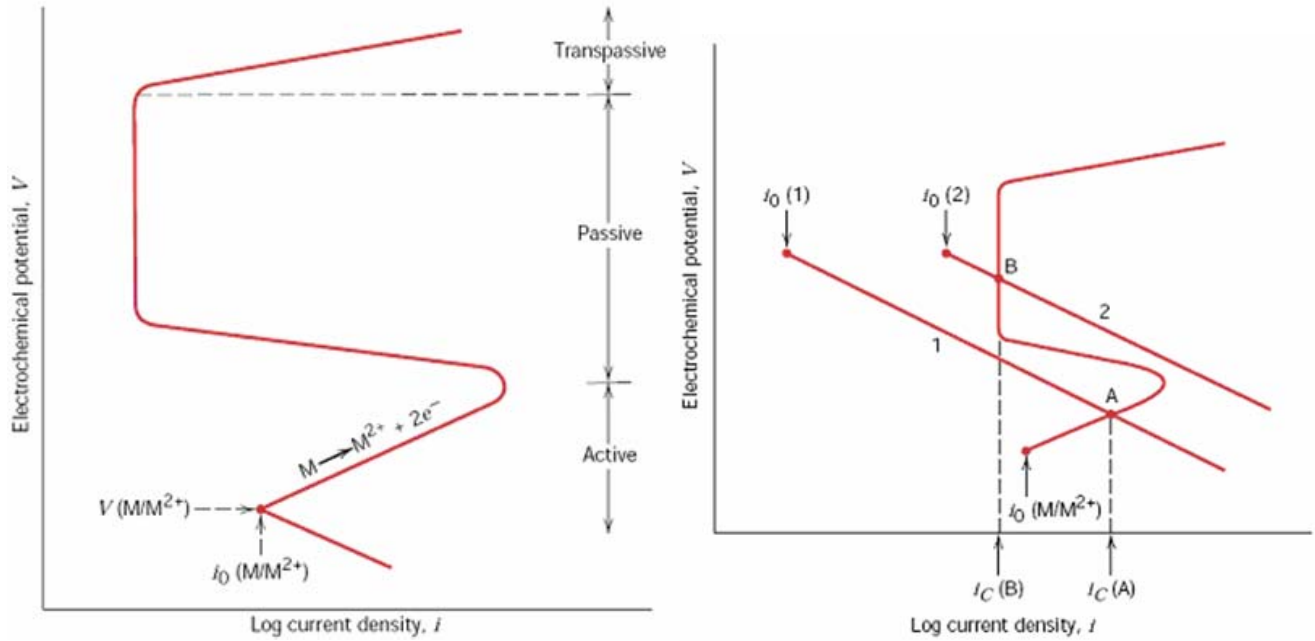

Figura 137 Tipos de corrosión

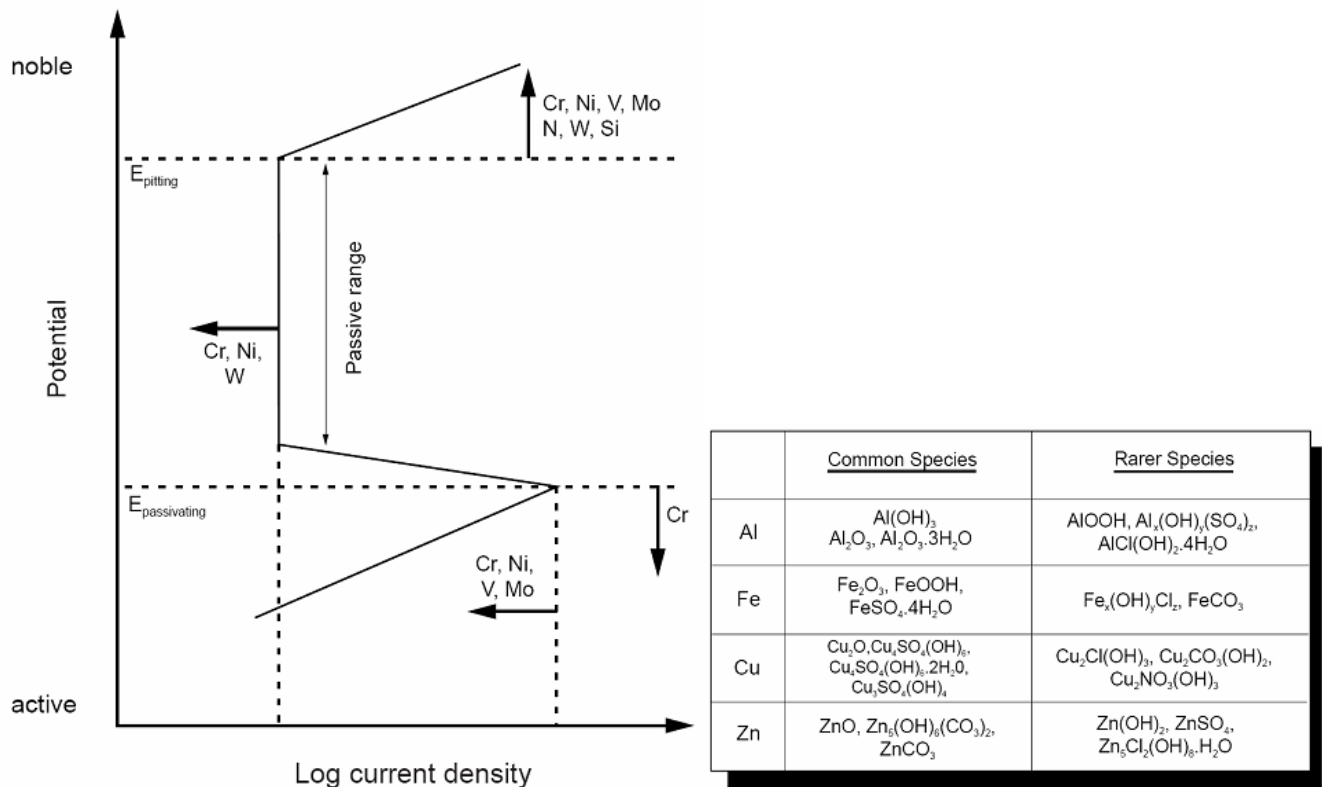

Figura 138 Representación esquemática de los cinco tipos de corrosión por penetración: general (incluyendo desgaste, erosión y fretting), intergranular, picadura, fractura por corrosión de esfuerzo y fractura por fatiga

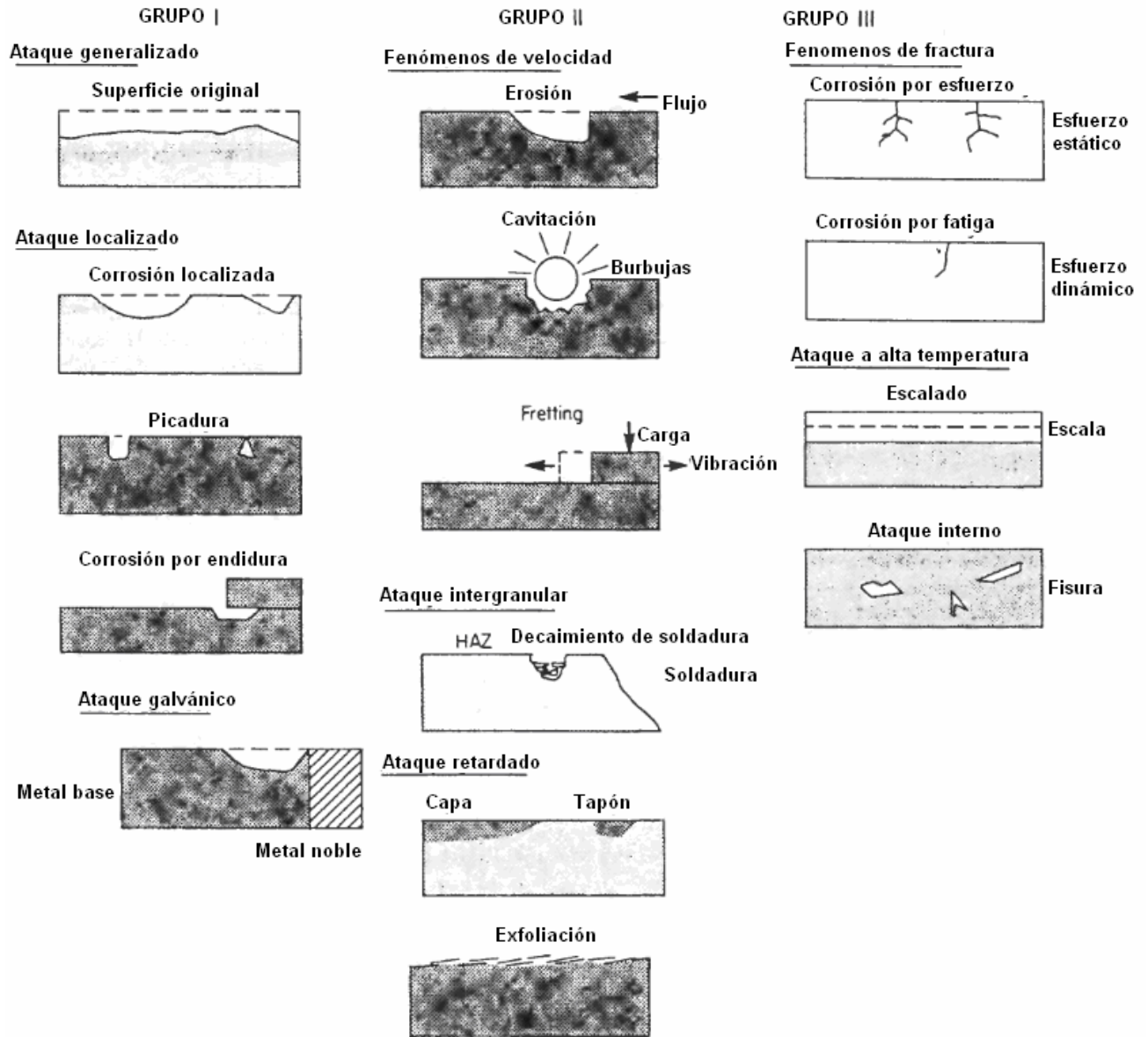

Figura 139 Corrosión por esfuerzo, intergranular y por fatiga

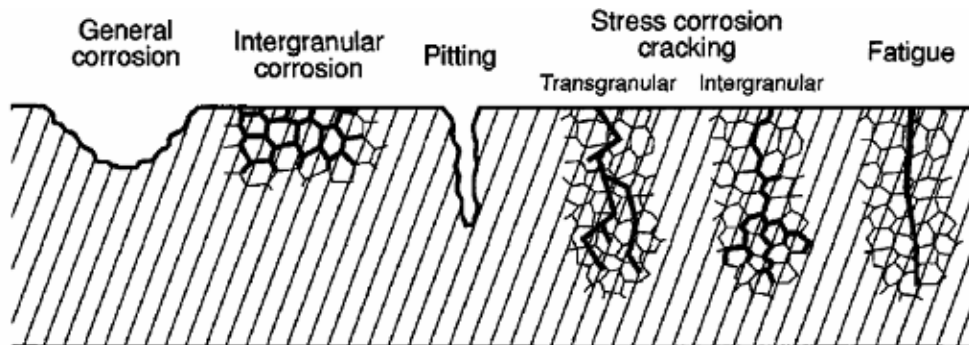

Figura 140 Corrosión- erosión

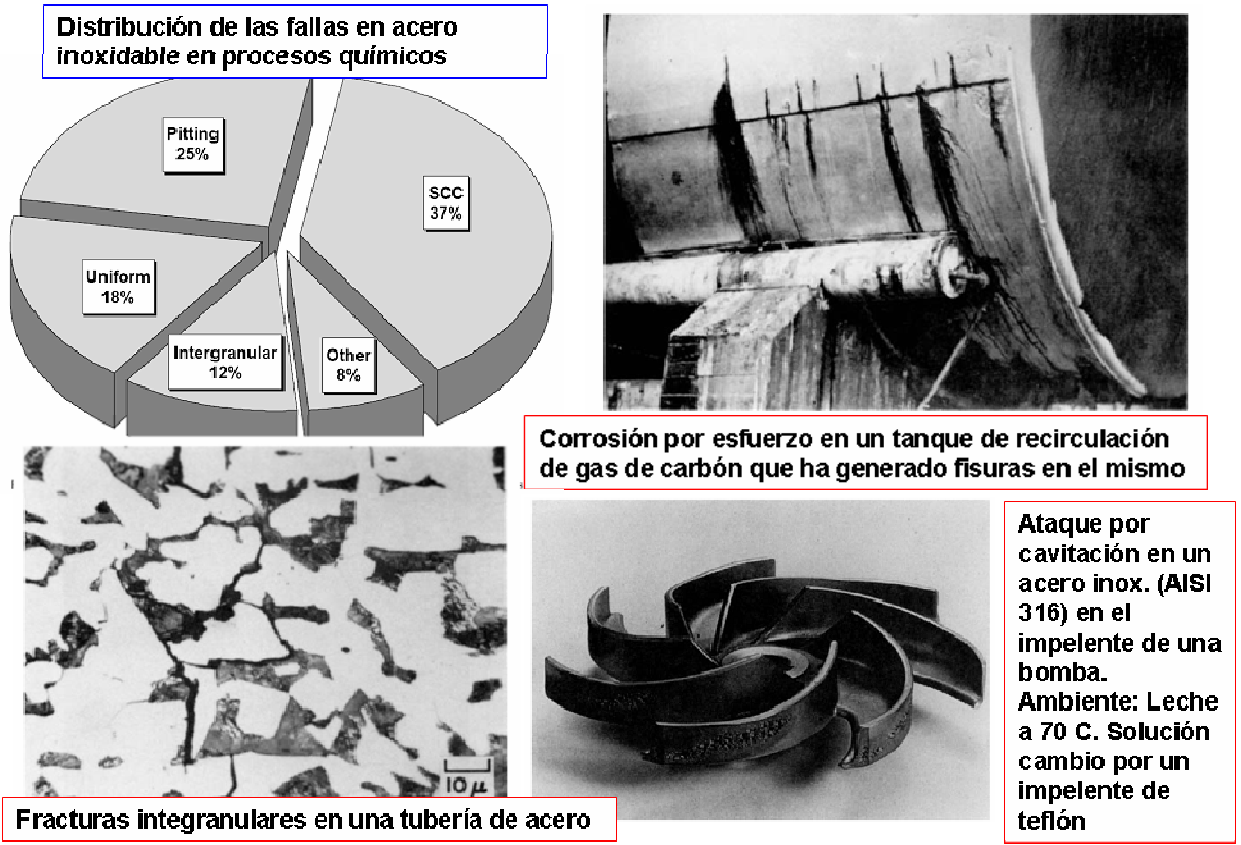

Figura 141 Una microfotografía epifluorescente de una población natural de bacterias incubadas en bajo nutriente e hidróxido de aluminio después de 1 año de incubación. Las bacterias son asociadas con las superficies de mineral precipitada (barra de escala, 5 μm)

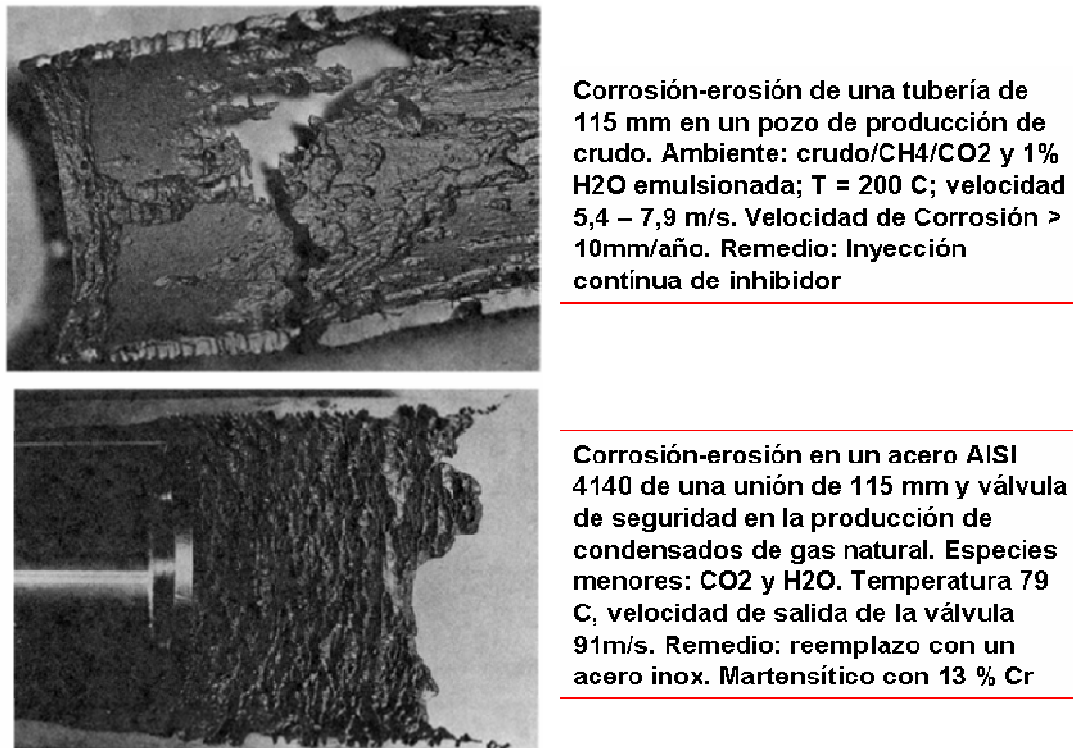

Progresión de flujo ilustrando la formación de vortices en la capa laminar y la evolución en turbulencia

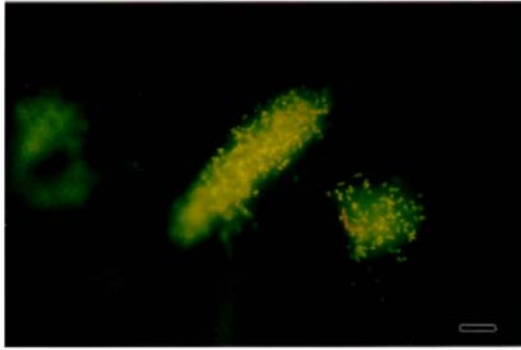
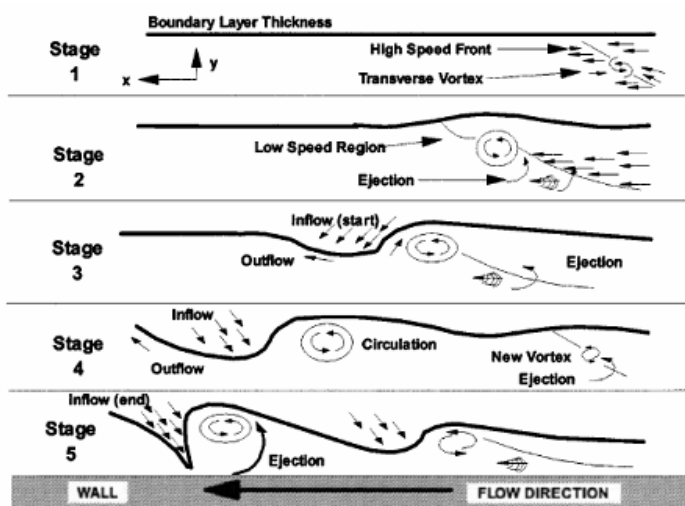
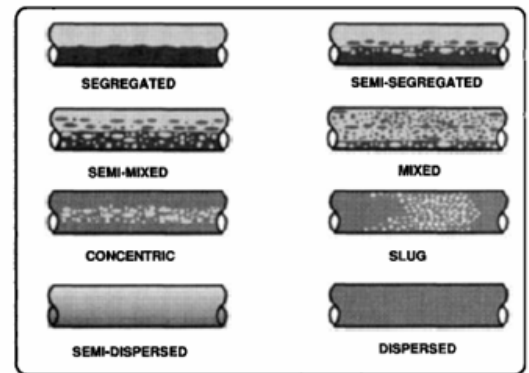

Regimenes de flujo para flujo de dos fases aceite/agua en tuberías horizontales

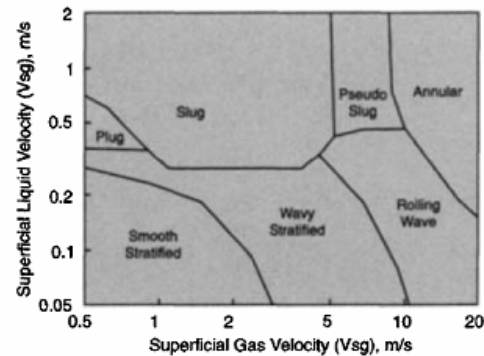
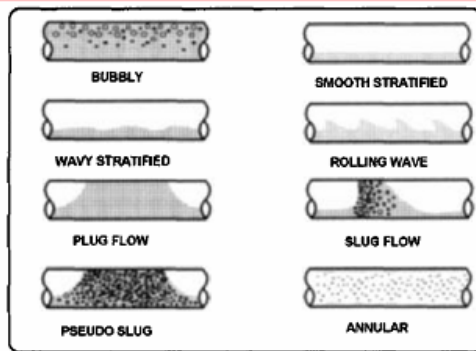

Regimenes de flujo y mapa de regimenes de flujo típicos para flujo de dos fases gas/agua en tuberías horizontales

Figura 142 Corrosión inducida por el flujo

1.9.5. Importancia de la protección contra la corrosión

La protección contra la corrosión depende principalmente del diseño inicial y del mantenimiento de los equipos que se encuentran en presencia de un ambiente fisicoquímico corrosivo.

Explosión de una tubería de aguas negras, México

Un ejemplo de daños de corrosión con responsabilidades compartidas fue la explosión que ocasionó la muerte de más de 200 personas en Guadalajara, México, en abril 1992. Además de las fatalidades, la serie de explosiones dañó 1600 edificios y lesionó 1500 personas. Los costos por los daños fueron estimados en 75 MM \$. La explosión fue rastreada hasta la instalación de una tubería de agua por una contratista varios años antes de la explosión que produjo una fuga de agua sobre una línea de gasolina subterránea. La corrosión subsecuente de la tubería de gasolina, produjo la fuga de gasolina dentro de las tuberías de aguas negras.

Tabla 28 Costos atribuidos a corrosión metálica en los Estados Unidos

	1975	1995
All industries		
Total (billions of 1995 dollars)	\$82.5	\$296.0
Avoidable	\$33.0	\$104.0
Avoidable	40%	35%
Motor vehicles		
Total	\$31.4	\$94.0
Avoidable	\$23.1	\$65.0
Avoidable	73%	69%
Aircraft		
Total	\$3.0	\$13.0
Avoidable	\$0.6	\$3.0
Avoidable	20%	23%
Other industries		
Total	\$47.6	\$189.0
Avoidable	\$9.3	\$36.0
Avoidable	19%	19%

1.9.6. Control y prevención de la corrosión

Mecanismo de corrosión ácida:

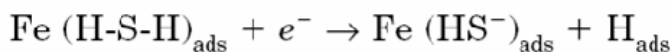
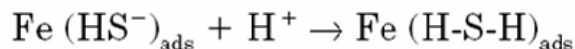
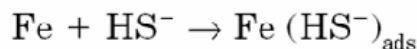
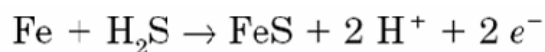

Protección anódica y catódica:

- Recubrimientos:
 - Metálicos (Cr-Ni-Cu-Zn),
 - Inorgánicos (Cerámicos),
 - Orgánicos (Resinas epóxicas)

- Corriente impresa (protección catódica):



Figura 143 Flujo de corriente y distribución en protección catódica de una tubería. Note el flujo de corriente para una tubería recubierta en una discontinuidad de recubrimiento.



Figura 144 Protección catódica para un tanque de almacenamiento de ácido sulfúrico

- Inhibidores de corrosión (protección anódica):

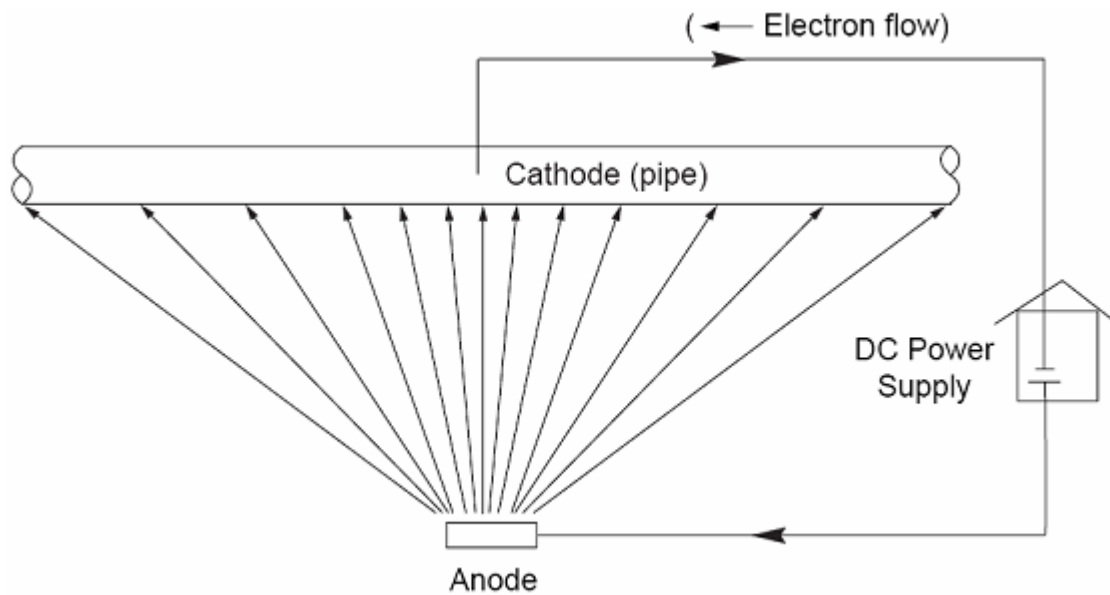
Tabla 29 Algunos sistemas corrosivos y los inhibidores utilizados para protegerlos

System	Inhibitor	Metals	Concentration
Acids			
HCl	Ethylaniline	Fe	0.5%
	MBT*	..	1%
	Pyridine + phenylhydrazine	..	0.5% + 0.5%
	Rosin amine + ethylene oxide	..	0.2%
H ₂ SO ₄	Phenylacridine	..	0.5%
H ₃ PO ₄	NaI	..	200 ppm
Others	Thiourea	..	1%
	Sulfonated castor oil	..	0.5–1.0%
	As ₂ O ₃	..	0.5%
	Na ₃ AsO ₄	..	0.5%
Water			
System	Inhibitor	Metals	Concentration
Potable	Ca(HCO ₃) ₂	Steel, cast iron	10 ppm
	Polyphosphate	Fe, Zn, Cu, Al	5–10 ppm
	Ca(OH) ₂	Fe, Zn, Cu	10 ppm
	Na ₂ SiO ₃	..	10–20 ppm
Cooling	Ca(HCO ₃) ₂	Steel, cast iron	10 ppm
	Na ₂ CrO ₄	Fe, Zn, Cu	0.1%
	NaNO ₂	Fe	0.05%
	NaH ₂ PO ₄	..	1%
	Morpholine	..	0.2%
Boilers	NaH ₂ PO ₄	Fe, Zn, Cu	10 ppm
	Polyphosphate	..	10 ppm
	Morpholine	Fe	Variable
	Hydrazine	..	O ₂ scavenger
	Ammonia	..	Neutralizer
	Octadecylamine	..	Variable
Engine coolants	Na ₂ CrO ₄	Fe, Pb, Cu, Zn	0.1–1%
	NaNO ₂	Fe	0.1–1%
	Borax	..	1%
Glycol/water	Borax + MBT*	All	1% + 0.1%
Oil field brines	Na ₂ SiO ₃	Fe	0.01%
	Quaternaries	..	10–25 ppm
	Imidazoline	..	10–25 ppm
Seawater	Na ₂ SiO ₃	Zn	10 ppm
	NaNO ₂	Fe	0.5%
	Ca(HCO ₃) ₂	All	pH dependent
	NaH ₂ PO ₄ + NaNO ₂	Fe	10 ppm + 0.5%

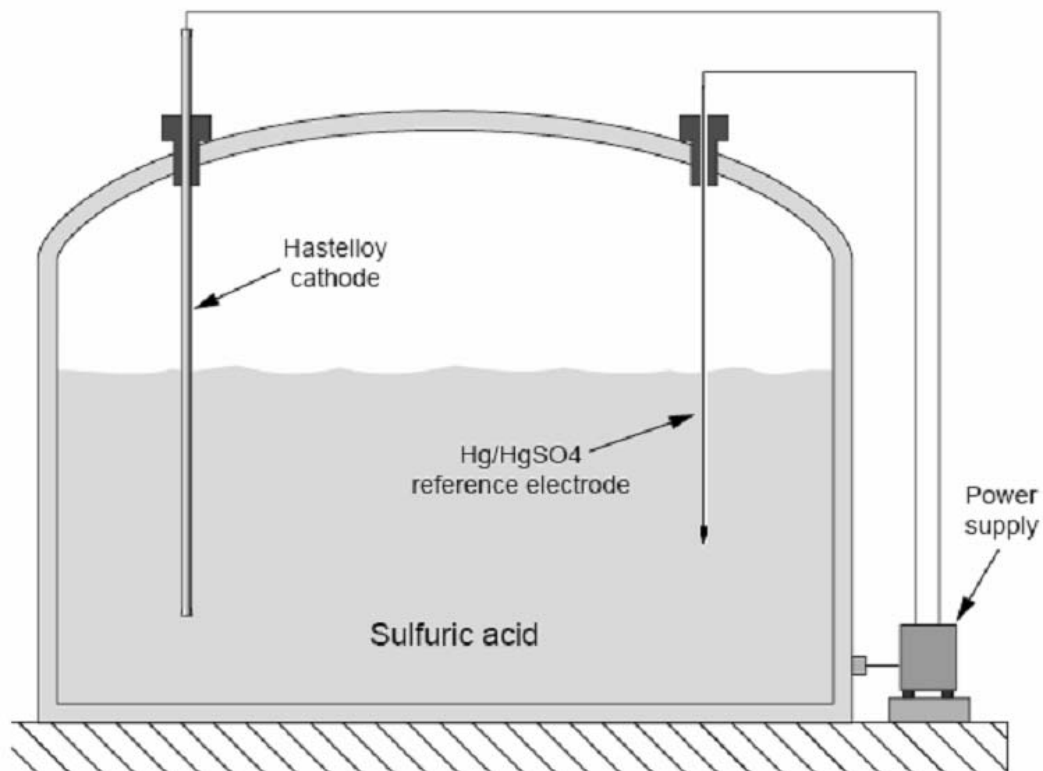
*MBT = mercaptobenzotriazole.



Figura 145 Control y prevención de la corrosión en el diseño

Causas de la corrosión en el diseño:

1. Metales diferentes
2. Drenaje inadecuado
3. Uniones entre metales y no metales
4. Endiduras
5. Corrientes residuales
6. Celdas complejas
7. Movimiento relativo entre dos partes interactuantes o entre una parte y su ambiente
8. Pérdida selectiva de uno o más componentes de una aleación
9. Imposibilidad de limpiar una superficie adecuadamente

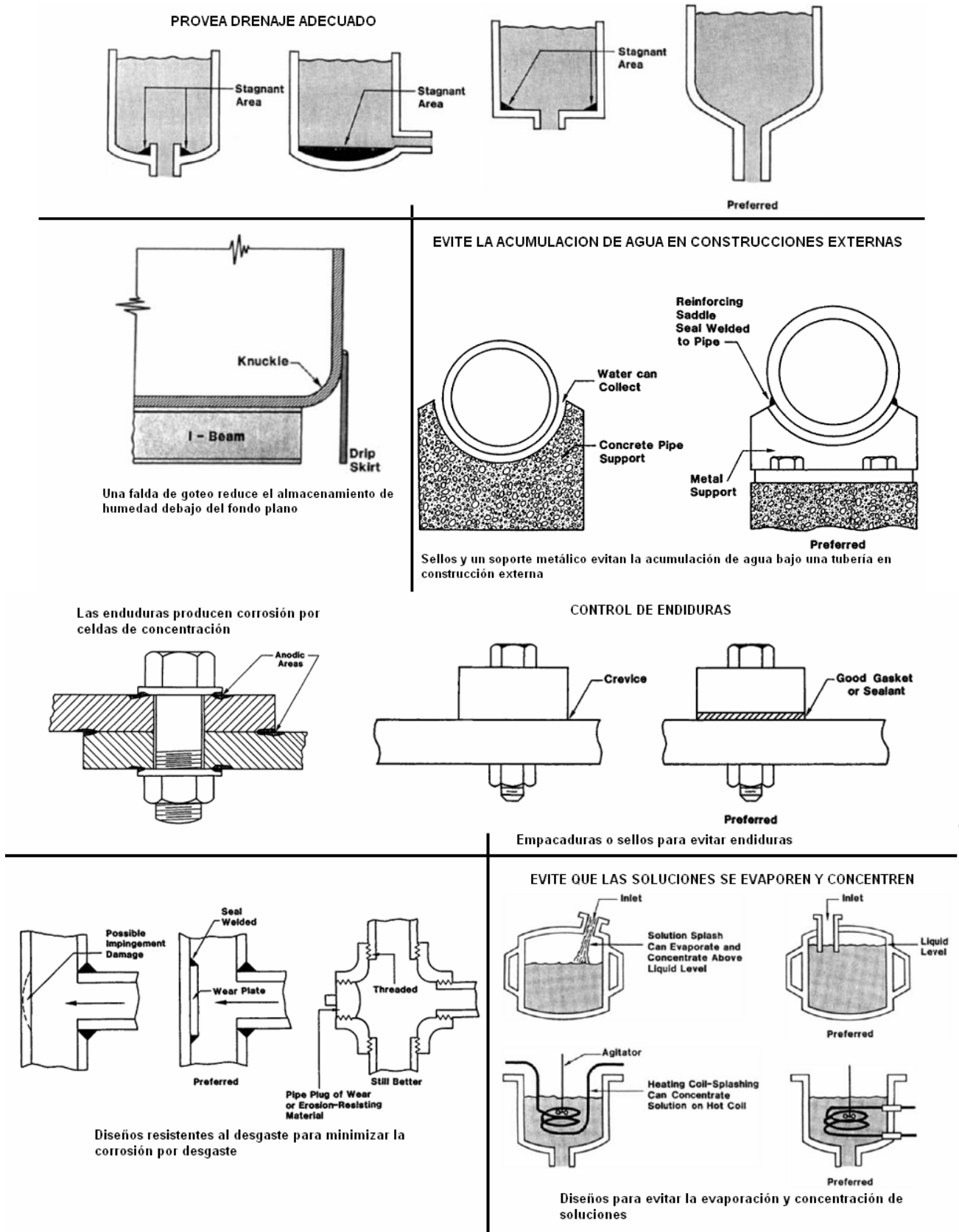

Figura 146 Control y prevención de la corrosión en el diseño

1.9.7. Corrosión en una Refinería de Petróleo



Figura 147 Operaciones de refinación de petróleo mostrando las especies corrosivas potenciales y los productos petroleros

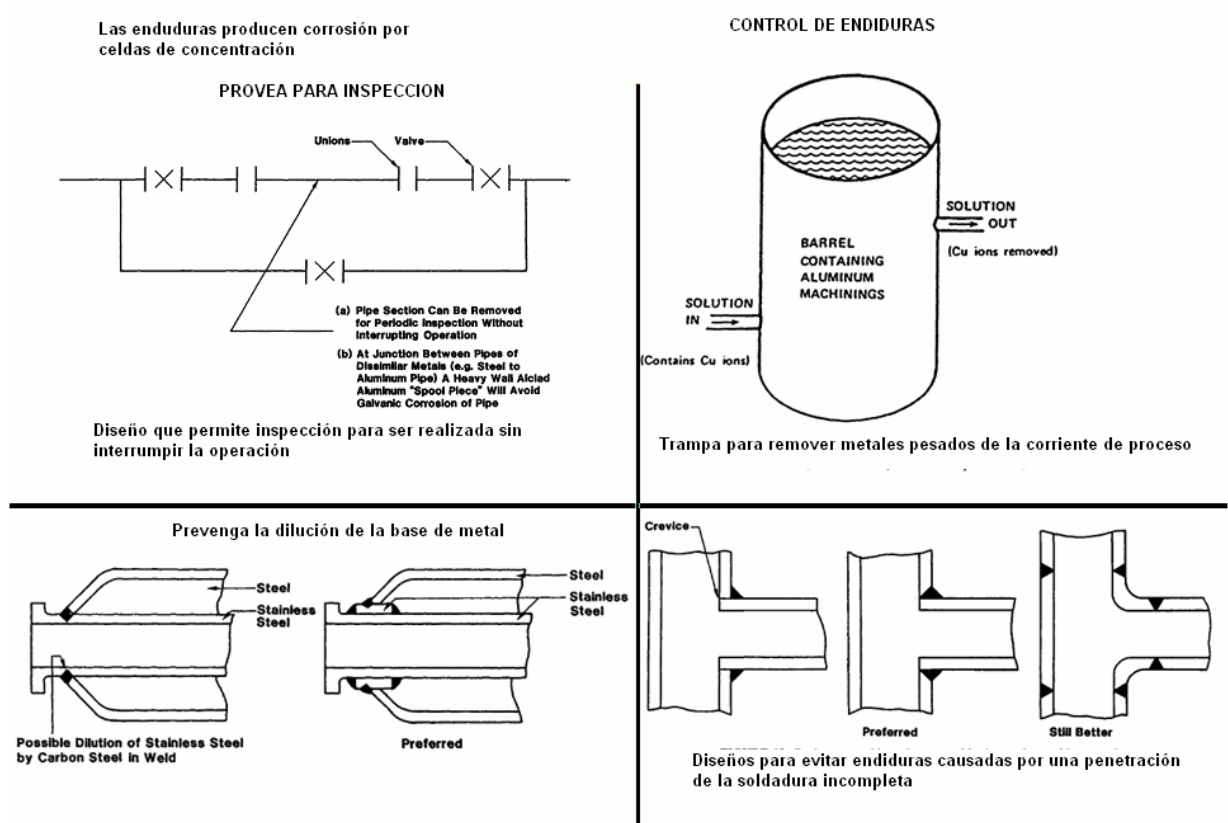

Figura 148 Destilación atmosférica de petróleo, se muestran las secciones donde puede existir corrosión

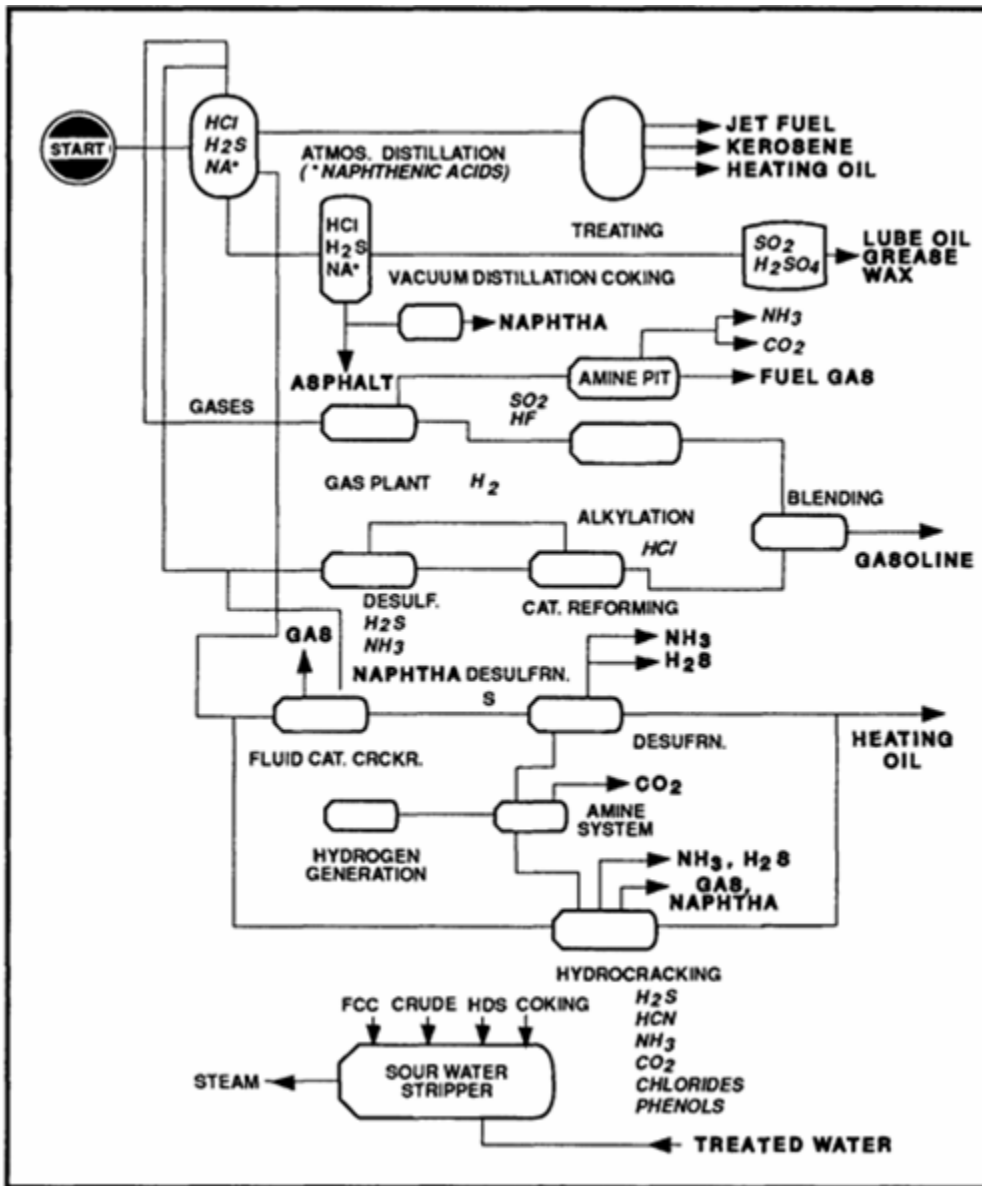

Figura 149 Destilación al vacío de petróleo

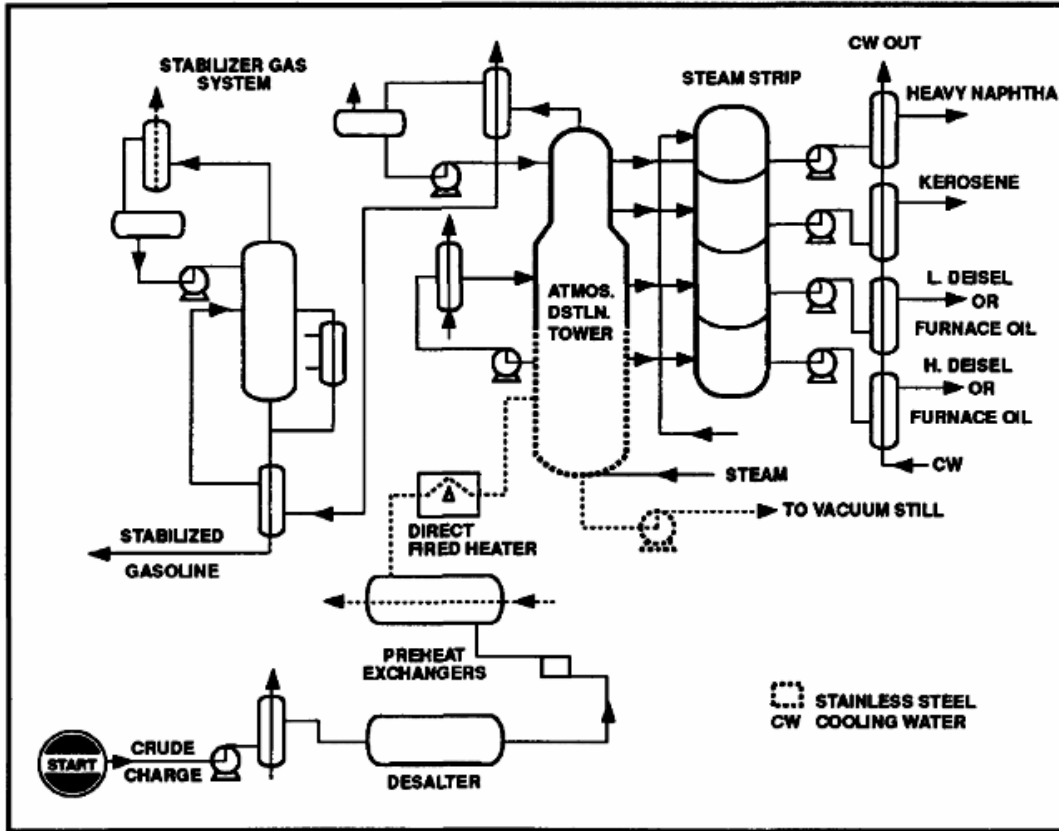

Figura 150 Coquificación retardada

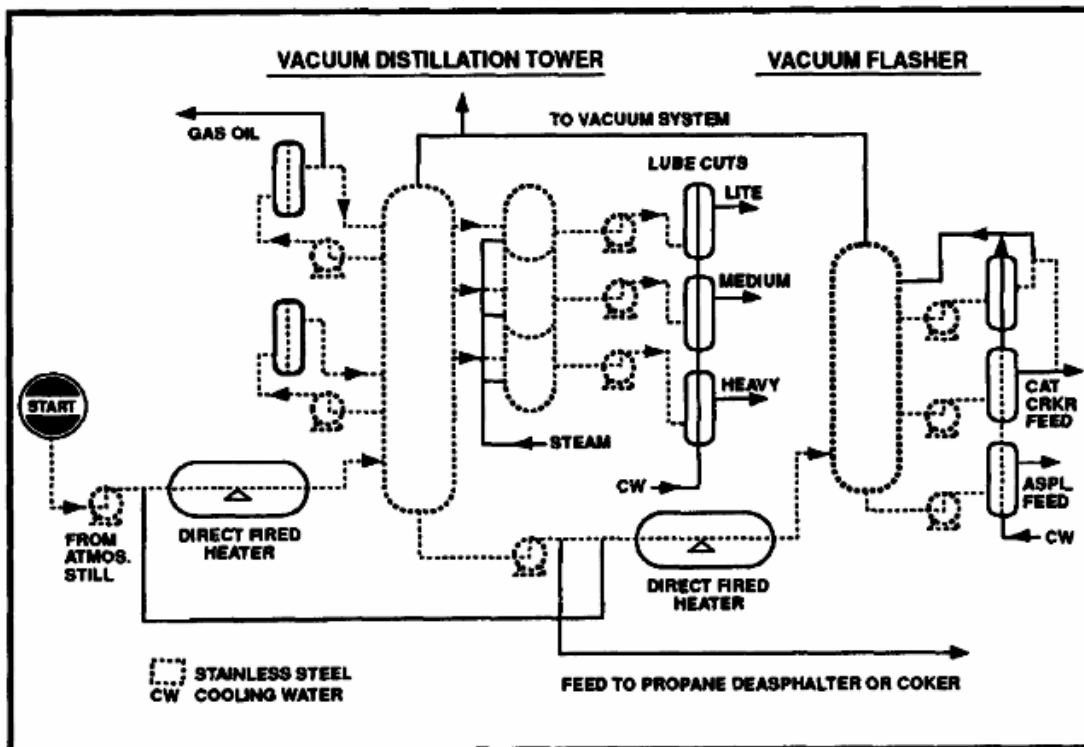

Figura 151 Fraccionadora de nafta

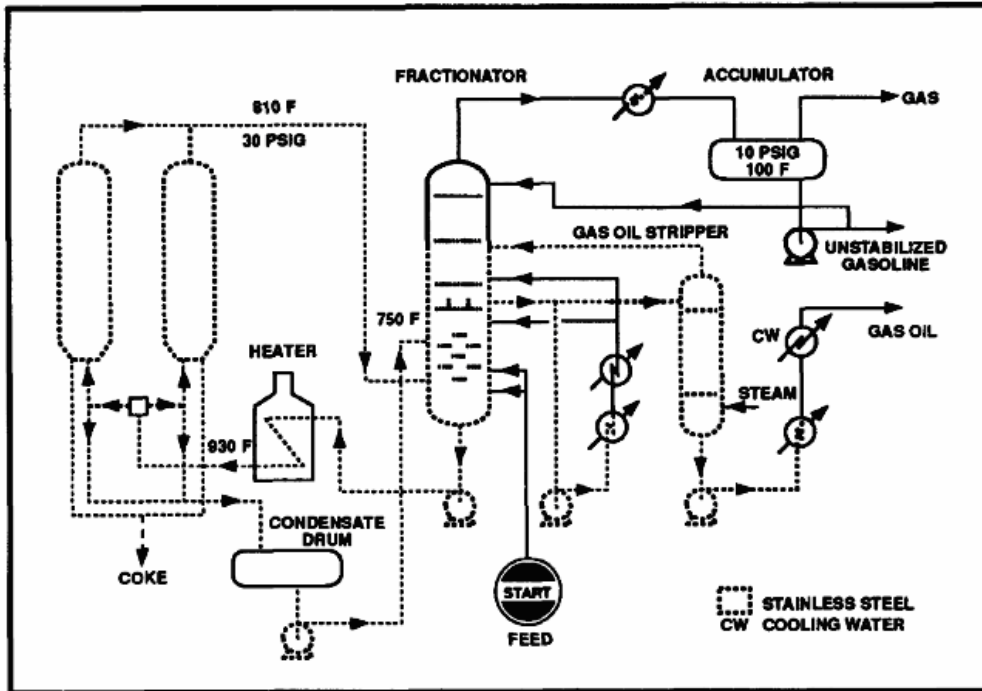

Figura 152 Endulzamiento de gases ácidos

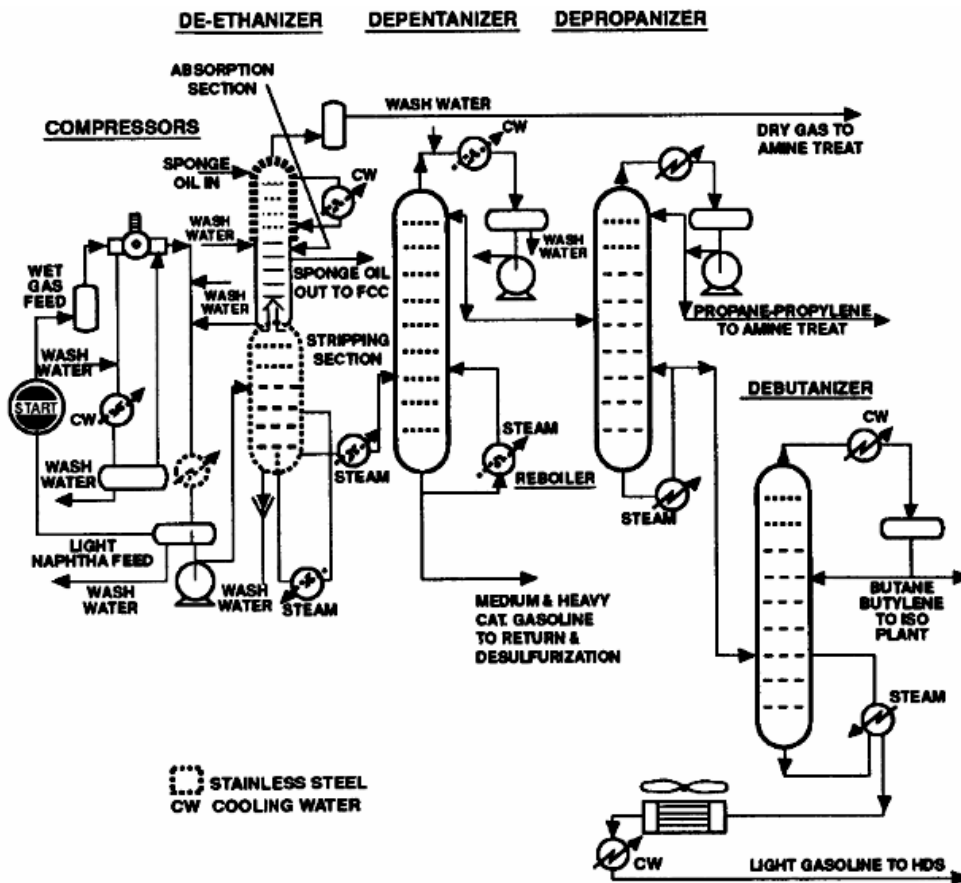

Figura 153 Alquilación con ácido sulfúrico

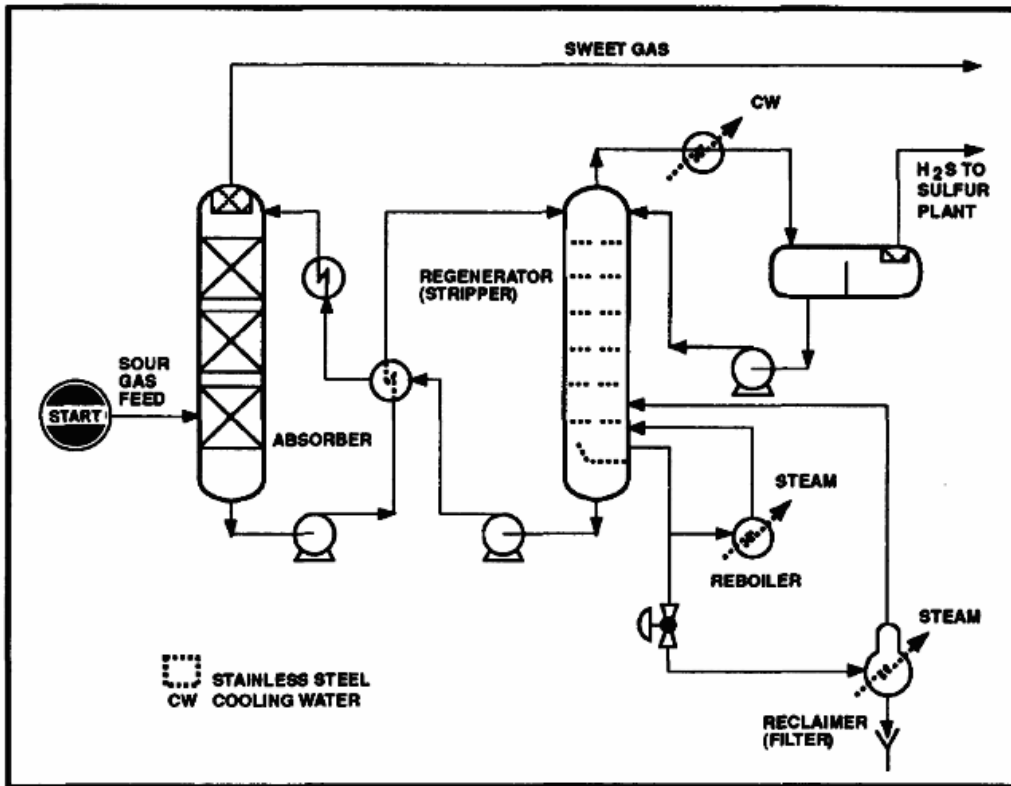

Figura 153 Hidrotratamiento

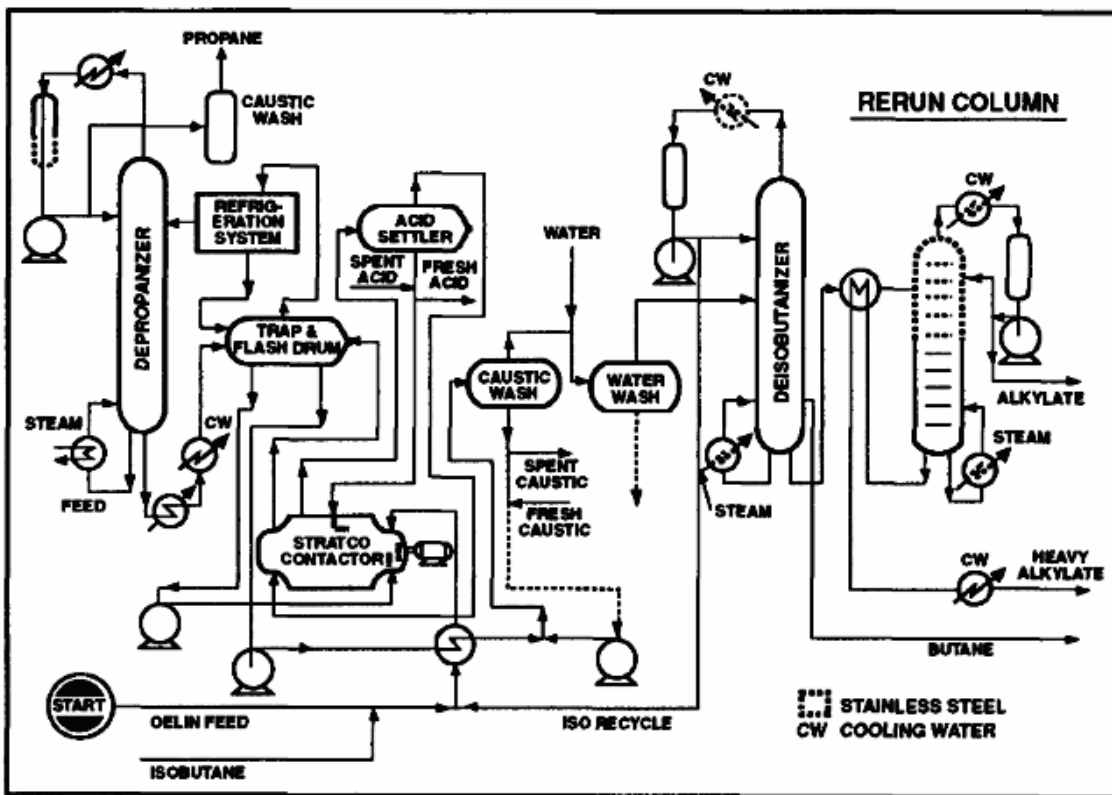

Figura 154 Reformado catalítico

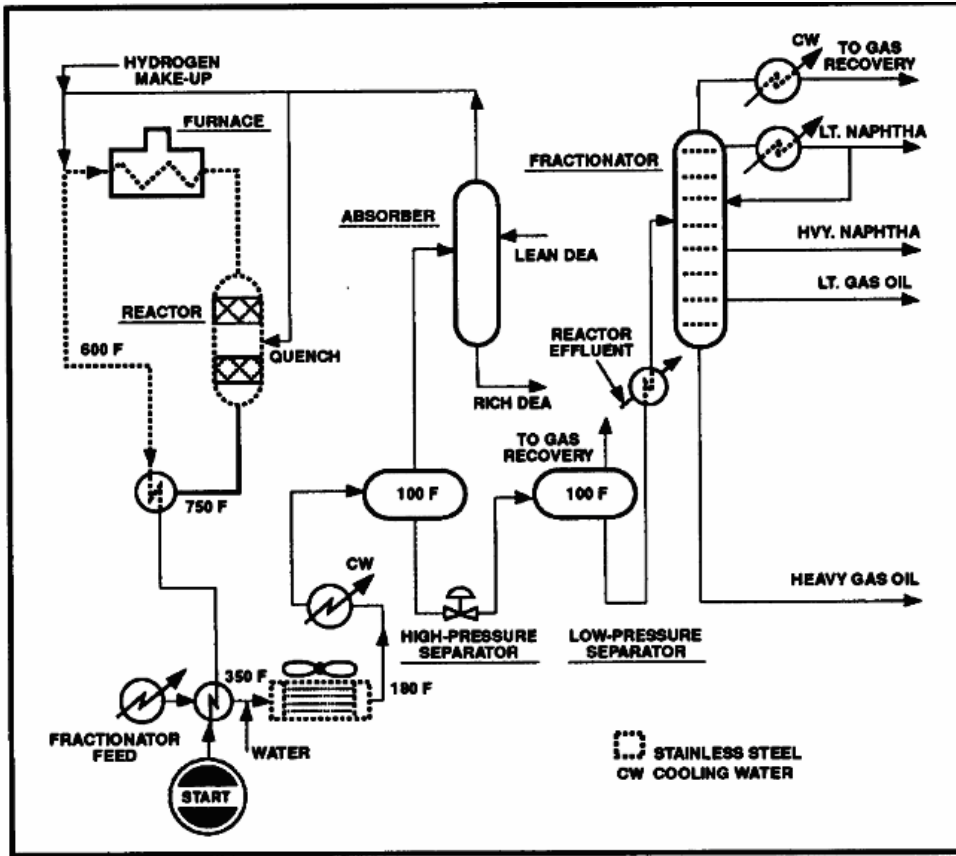

Figura 155 Craqueo catalítico fluidizado

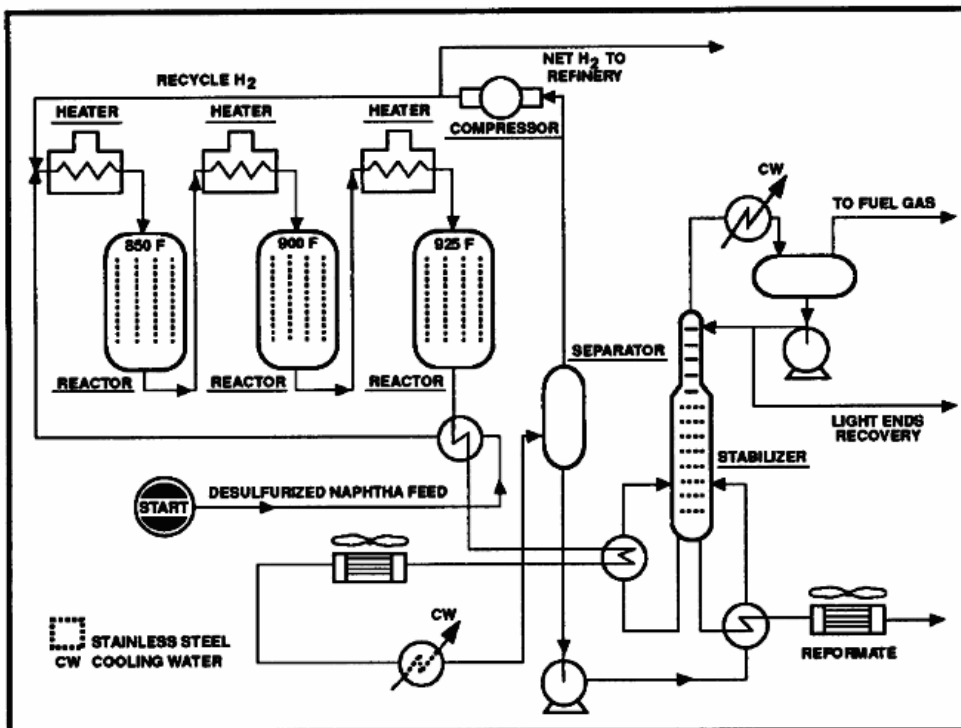

Figura 156 Hidrocrqueo

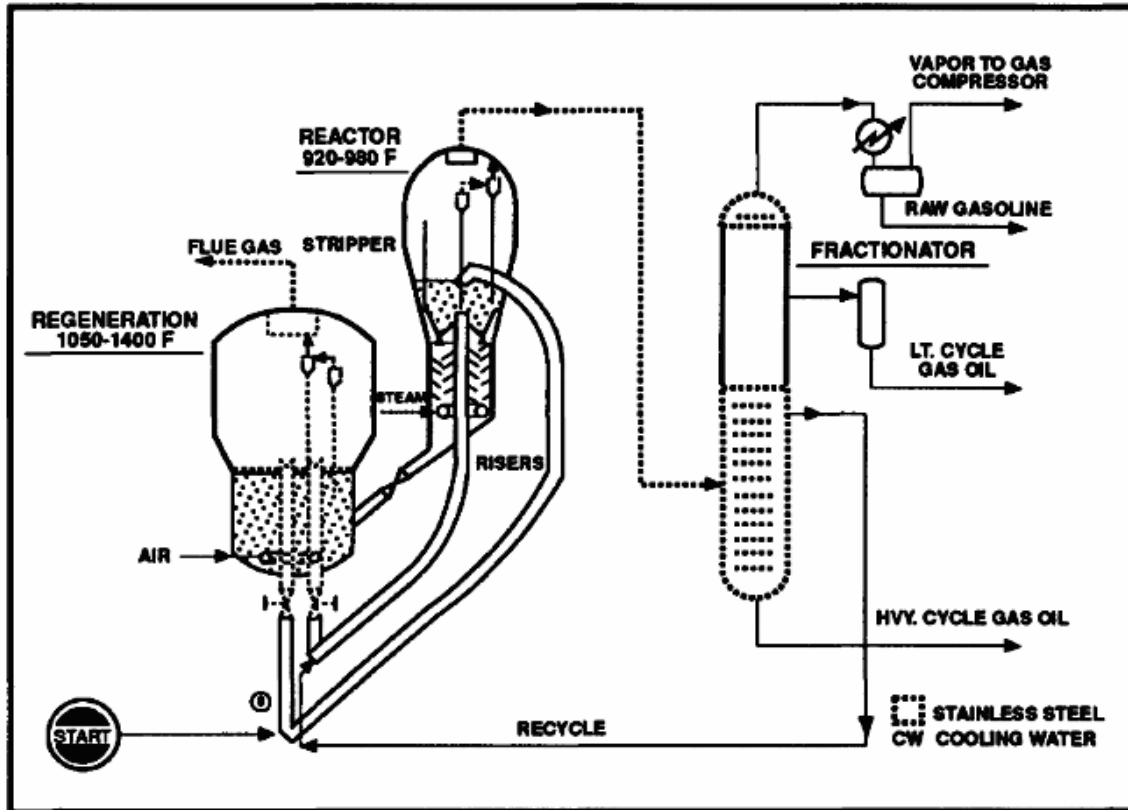

Figura 157 Planta de hidrógeno

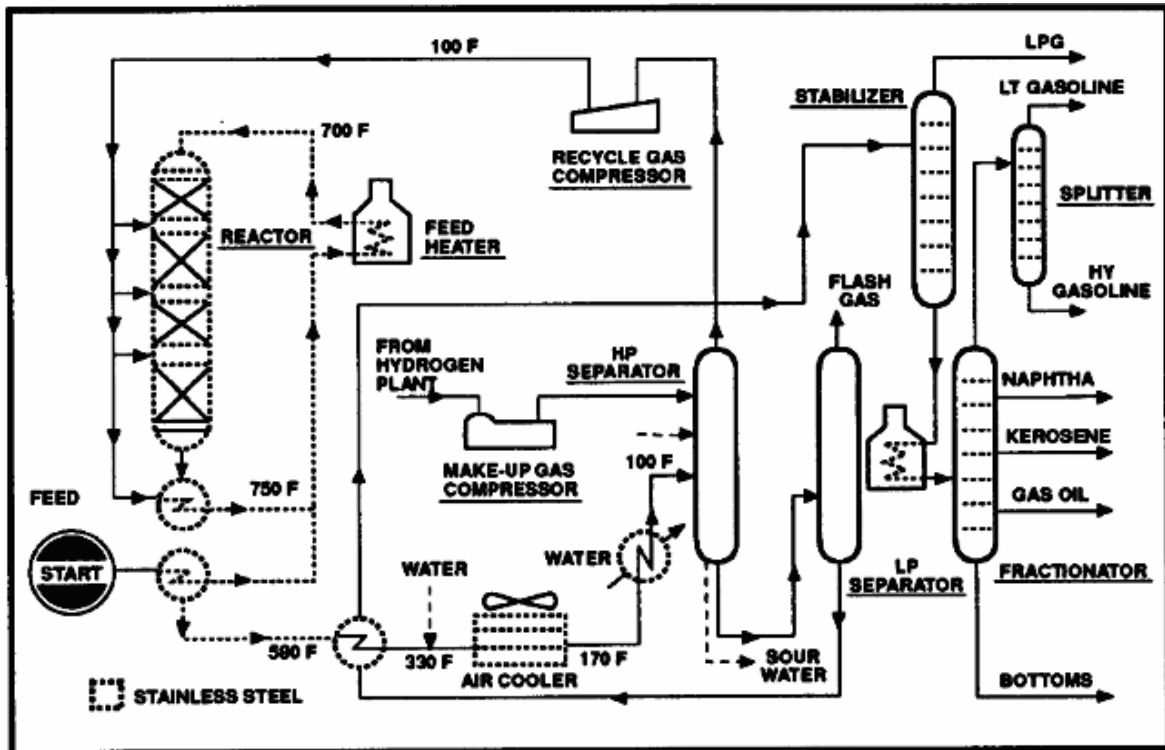

Figura 158 Despojador de aguas agrias

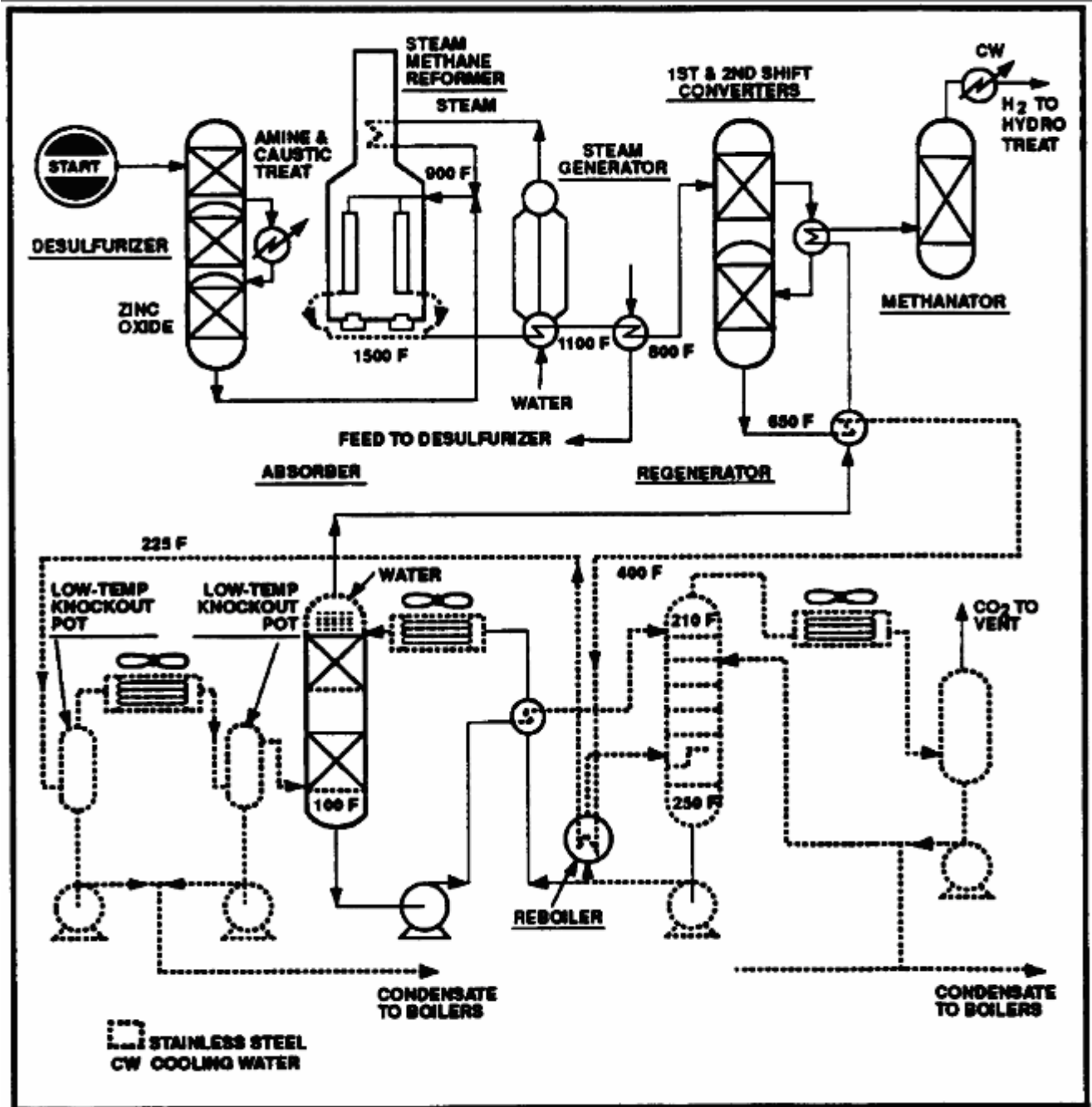

Figura 159 Planta recuperadora de azufre (Claus) de una sola etapa

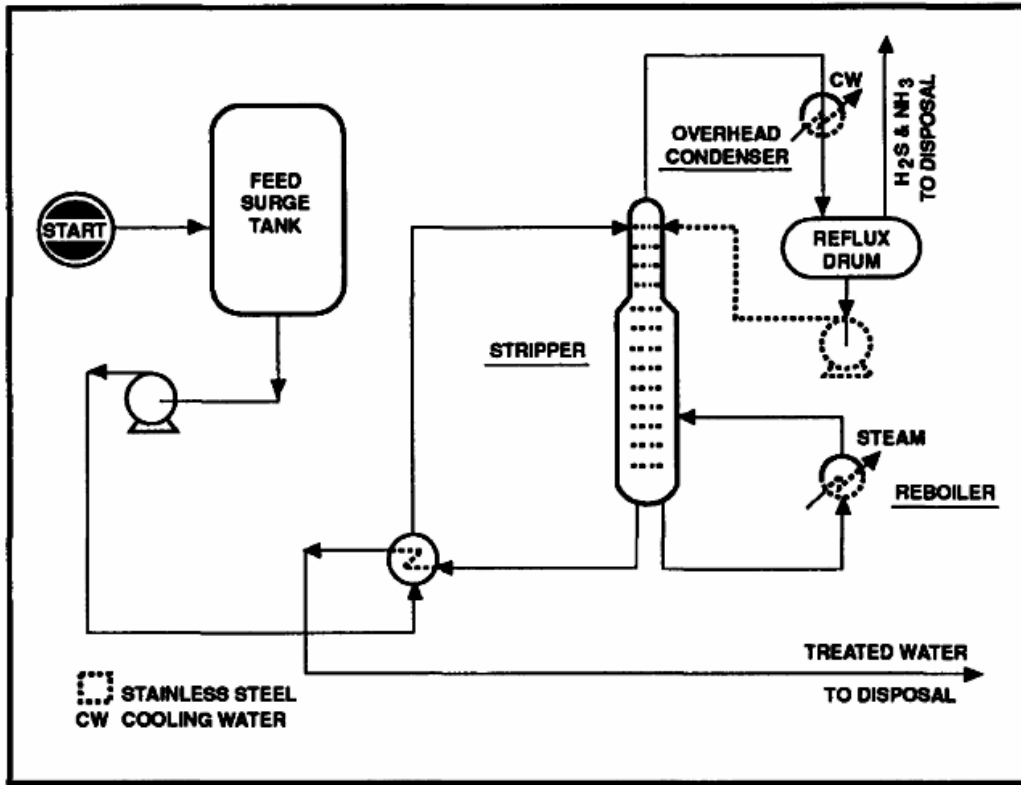

Figura 160 Efectos de la presión parcial de CO₂ y H₂S en la selección de aleaciones

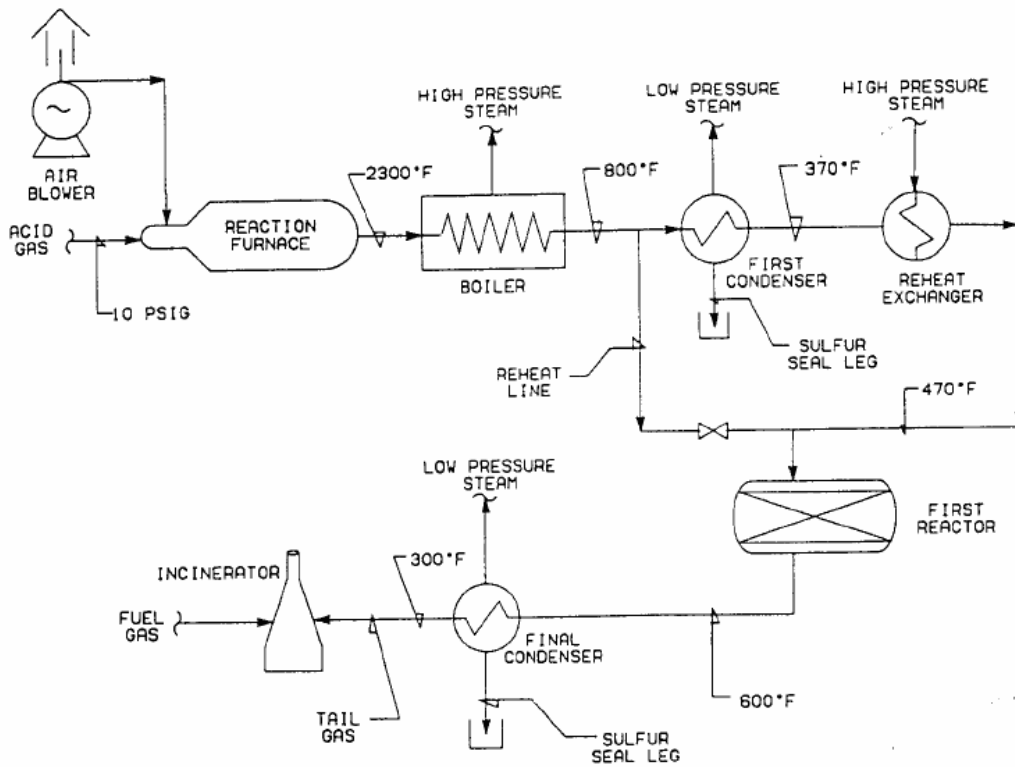

Figura 161 Tuberías de acero inoxidable vs acero al carbono, efecto de la distancia de la costa

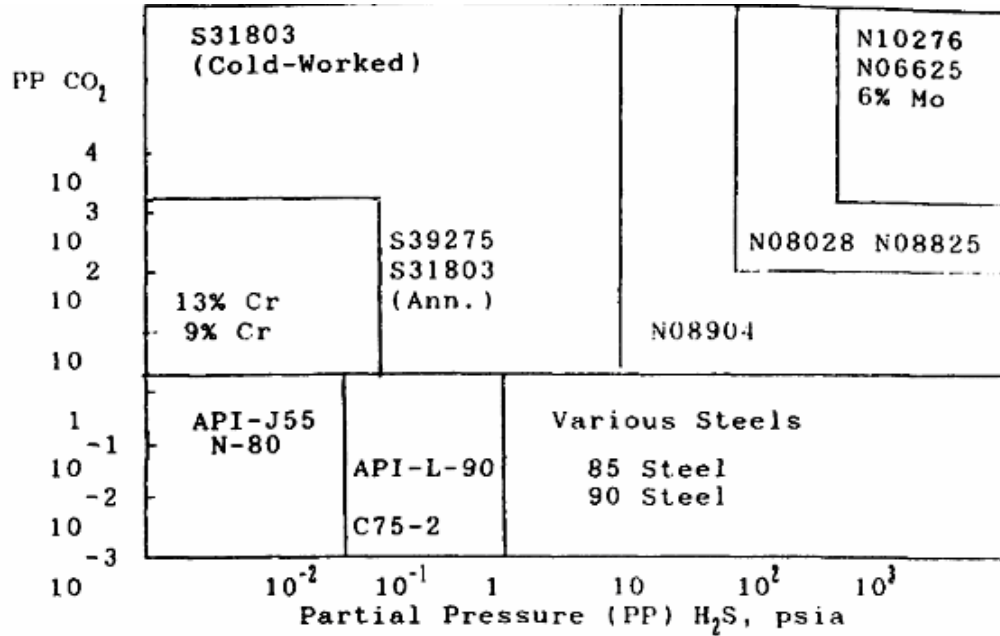

Figura 162 Corrosión con HCl, aleaciones resistentes a la corrosión con respecto a la concentración de ácido

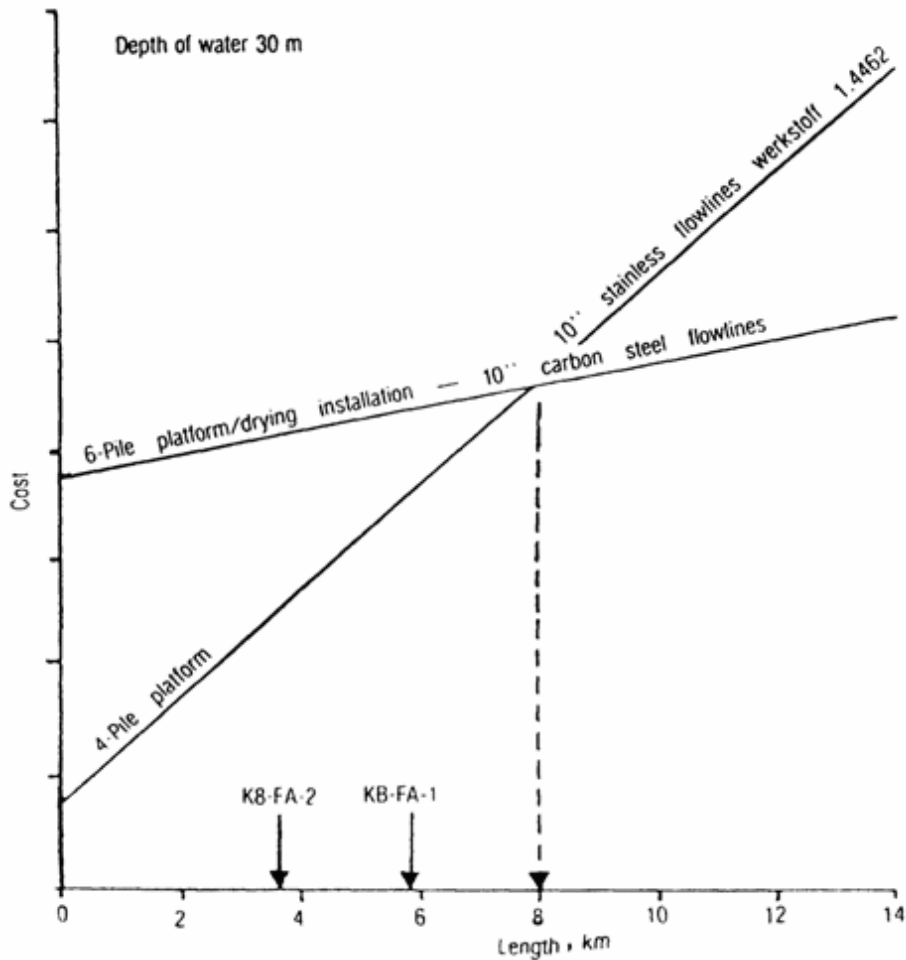

Materials in shaded zones have reported corrosion rates of $< 0.5 \text{ mm}\cdot\text{y}^{-1}$

Zone 1	Zone 2	Zone 3	Zone 4	Zone 5
20Cr 30Ni	18Cr 8Ni	20Cr 30Ni	18Cr 8Ni	18Cr 8Ni
Gold	20Cr 30Ni	Gold	20Cr 30Ni	20Cr 30Ni
Lead	Cast Iron	Platinum	Gold	Aluminum
Platinum	Gold	Silicon Iron	Platinum	Gold
Silicon Iron	Lead	Tantalum	Silicon iron	Platinum
Steel	Platinum		Tantalum	Silicon Iron
Tantalum	Silicon Iron			Tantalum
	Tantalum			

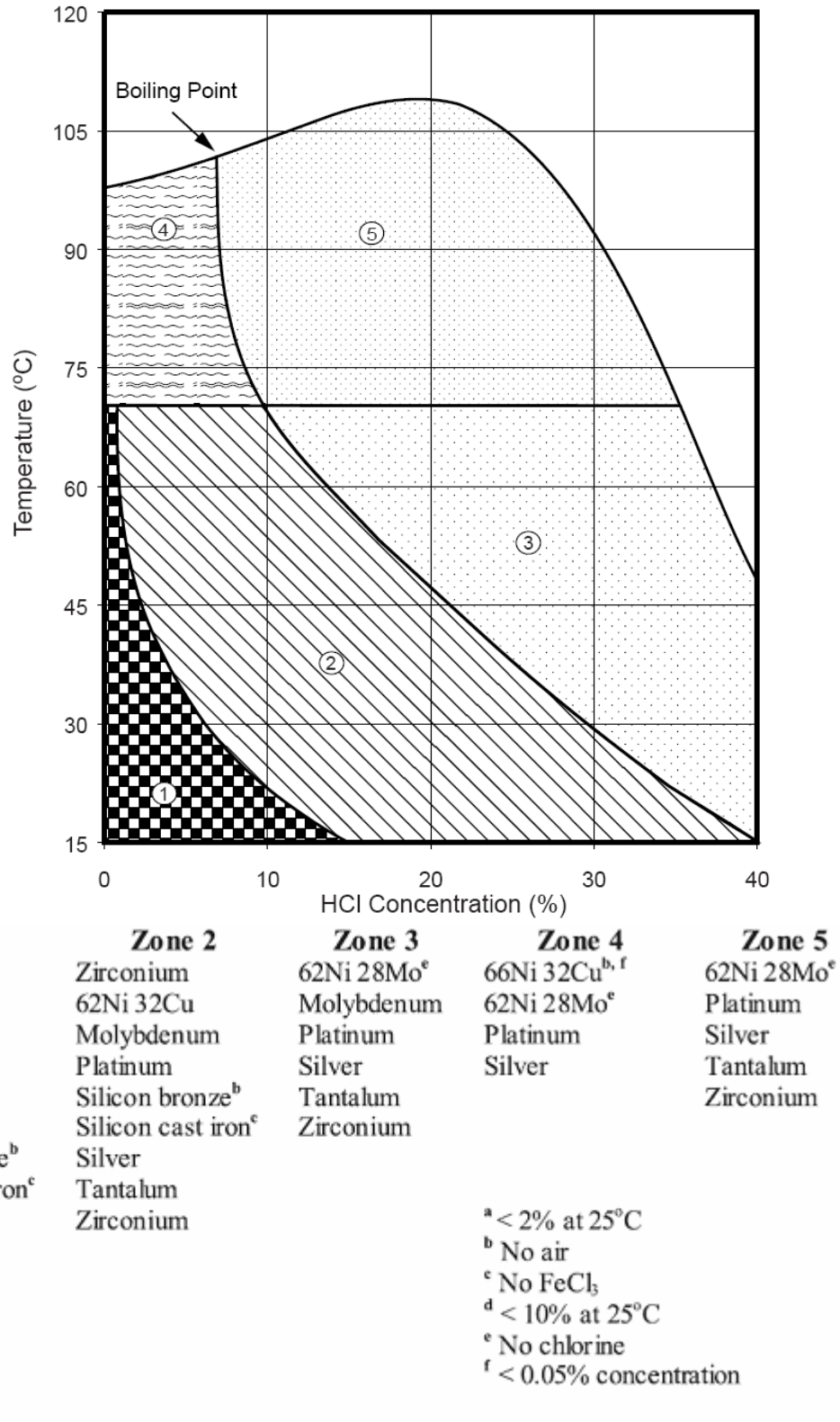
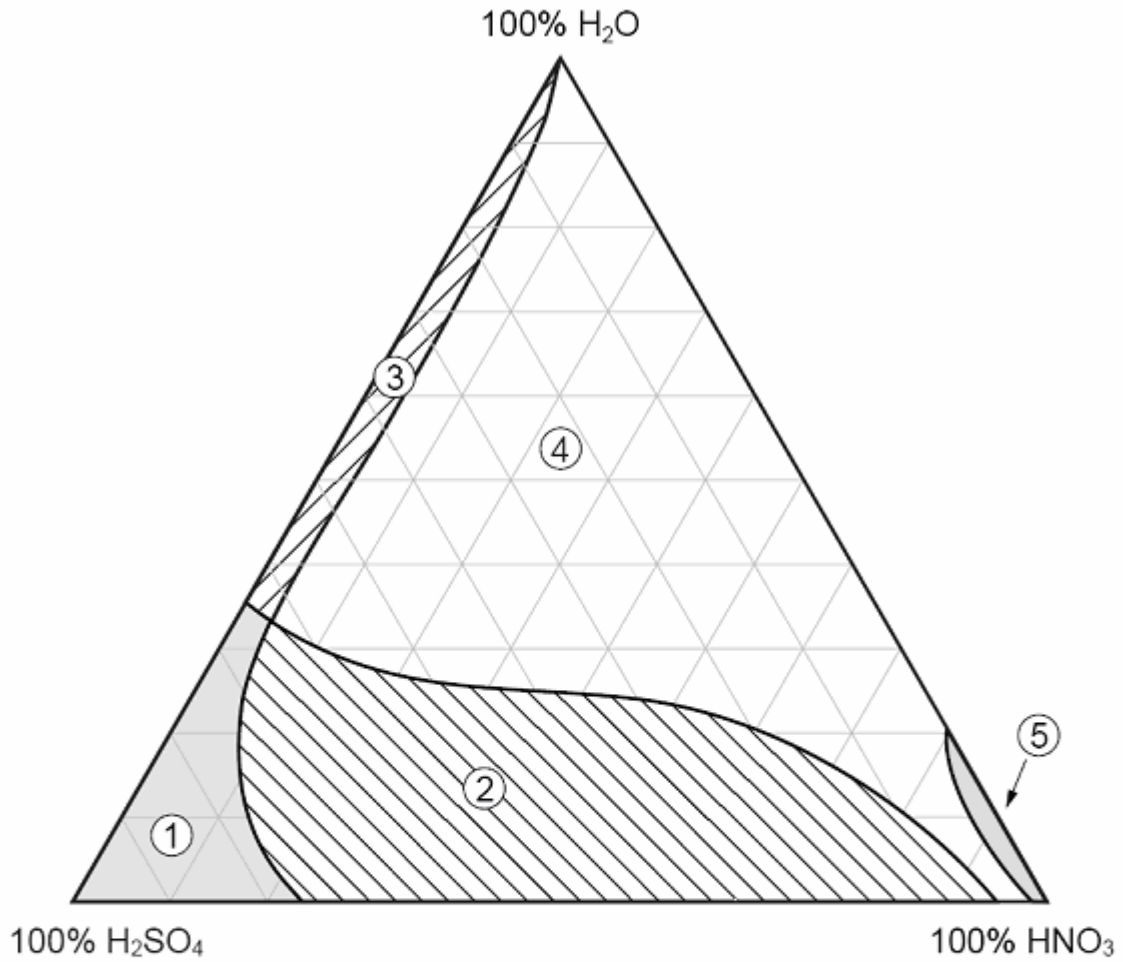
Figura 163 Gráfico de mezcla de ácidos

1.9.8. Descripción de aleaciones utilizadas para la prevención de corrosión

Hastelloy C-276 (N10276)

Description and corrosion resistance. This is a nickel-chromium-molybdenum wrought alloy that is considered the most versatile corrosion-resistant alloy available. It is resistant to the formation of grain boundary precipitates in the weld heat-affected zone, thus making it suitable for most chemical process applications in an as-welded condition. Alloy C-276 also has excellent resistance to pitting, stress-corrosion cracking, and oxidizing atmospheres up to 1050°C. It has exceptional resistance to a wide variety of chemical environments and outstanding resistance to a wide variety of chemical process environments including ferric and cupric chlorides, hot contaminated mineral acids, solvents, chlorine and chlorine contamination (both organic and inorganic), dry chlorine, formic and acetic acids, acetic anhydride, seawater and brine solutions, and hypochlorite and chlorine dioxide solutions. It is one of the few alloys resistant to wet chloride gas, hypochlorite, and chlorine dioxide solutions and has exceptional resistance to strong solutions of oxidizing salts, such as ferric and cupric chlorides.

Applications. Some typical applications include equipment components in chemical and petrochemical organic chloride processes and processes utilizing halide or acid catalysts. Other industry applications are pulp and paper digesters and bleach areas, scrubbers and ducting for flue gas desulfurization, pharmaceutical and food processing equipment.

Incoloy 800 (N08800)

Description and corrosion resistance. Alloy 800 is a nickel-iron-chromium alloy with good strength and excellent resistance to oxidation and carburization in high-temperature atmospheres. It also resists corrosion by many aqueous environments. The alloy maintains a stable, austenitic structure during prolonged exposure to high temperatures.

Applications. Uses for Incoloy 800 include

- Process piping
- Heat exchangers
- Carburizing equipment
- Heating-element sheathing
- Nuclear steam-generator tubing

 Inconel 600 (N06600)

Description and corrosion resistance. Alloy 600 is a nickel-chromium alloy designed for use from cryogenic to elevated temperatures in the range of 1093°C. The high nickel content of the alloy enables it to retain considerable resistance under reducing conditions and makes it resistant to corrosion by a number of organic and inorganic compounds. The nickel content gives it excellent resistance to chloride-ion stress corrosion cracking and also provides excellent resistance to alkaline solutions.

Its chromium content gives the alloy resistance to sulfur compounds and various oxidizing environments. The chromium content of the alloy makes it superior to commercially pure nickel under oxidizing conditions. In strong oxidizing solutions like hot, concentrated nitric acid, 600 has poor resistance. Alloy 600 is relatively unattacked by the majority of neutral and alkaline salt solutions and is used in some caustic environments. The alloy resists steam and mixtures of steam, air, and carbon dioxide.

Alloy 600 is nonmagnetic, has excellent mechanical properties and a combination of high strength and good workability, and is readily weldable. Alloy 600 exhibits cold-forming characteristics normally associated with chromium-nickel stainless steels. It is resistant to a wide range of corrosive media. The chromium content gives better resistance than Alloys 200 and 201 under oxidizing conditions, and at the same time the high nickel gives good resistance to reducing conditions. Other qualities are as follows:

Virtually immune to chlorine ion stress corrosion cracking.

Demonstrates adequate resistance to organic acids such as acetic, formic, and stearic. Excellent resistance to high purity water used in primary and secondary circuits of pressurized nuclear reactors.

Little or no attack occurs at room and elevated temperatures in dry gases, such as chlorine or hydrogen chloride. At temperatures up to 550°C in these media, this alloy has been shown to be one of the most resistant of the common alloys.

At elevated temperatures the annealed and solution annealed alloy shows good resistance to scaling and has high strength.

The alloy also resists ammonia-bearing atmospheres, as well as nitrogen and carburizing gases.

Under alternating oxidizing and reducing conditions the alloy may suffer from selective oxidation.

Applications. Typical corrosion applications include titanium dioxide production (chloride route), perchlorethylene syntheses, vinyl chloride monomer (VCM), and magnesium chloride. Alloy 600 is used in chemical and food processing, heat treating, phenol condensers, soap manufacture, vegetable and fatty acid vessels, among other uses. In nuclear reactors uses are for such components as control rod inlet stub tubes, reactor vessel components and seals, steam dryers, and separators in boiling water reactors. In pressurized water reactors it is used for control rod guide tubes and steam generator baffle plates. Other uses include

Thermocouple sheaths

Ethylene dichloride (EDC) cracking tubes

Conversion of uranium dioxide to tetrafluoride in contact with hydrofluoric acid

Production of caustic alkalis, particularly in the presence of sulfur compounds

Reactor vessels and heat-exchanger tubing used in the production of vinyl chloride

Process equipment used in the production of chlorinated and fluorinated hydrocarbons

Furnace retort seals, fans, and fixtures

Roller hearths and radiant tubes, in carbonitriding processes especially

Monel 400 (N04400)

Description and corrosion resistance. Alloy 400 is a nickel-copper alloy with excellent corrosion resistance in a wide variety of media. The alloy is characterized by good general corrosion resistance, good weldability, and moderate-to-high strength. The alloy has been used in a variety of applications. It has excellent resistance to rapidly flowing brackish water and seawater. It is particularly resistant to hydrochloric and hydrofluoric acids when they are deaerated. The alloy is slightly magnetic at room temperature and is widely used in the chemical, oil, and marine industries.

It has a good corrosion resistance in an extensive range of marine and chemical environments, from pure water to nonoxidizing mineral acids, salts, and alkalis. This alloy is more resistant than nickel under reducing conditions and more resistant than copper under oxidizing conditions. It does show, however, better resistance to reducing media than oxidizing ones. It also has

Good mechanical properties from subzero temperatures up to about 480°C.

Good resistance to sulfuric and hydrofluoric acids. Aeration, however, will result in increased corrosion rates. It may be used to handle hydrochloric acid, but the presence of oxidizing salts will greatly accelerate corrosive attack.

Resistance to neutral, alkaline, and acid salts is shown, but poor resistance is found with oxidizing acid salts such as ferric chloride.

Excellent resistance to chloride ion stress corrosion cracking.

Applications. Uses for Monel 400 include

Feed water and steam generator tubing

Brine heaters and seawater scrubbers in tanker inert gas systems

Sulfuric acid and hydrofluoric acid alkylation plants

Pickling bath heating coils

Heat exchangers in a variety of industries

Transfer piping from oil refinery crude columns

Plants for the refining of uranium and isotope separation in the production of nuclear fuel

Pumps and valves used in the manufacture of perchlorethylene, chlorinated plastics

Monoethanolamine (MEA) reboiling tubes

Cladding for the upper areas of oil refinery crude columns

Propeller and pump shafts

Nickel 200 (N02200)

Description and corrosion resistance. This is commercially pure wrought nickel with good mechanical properties over a wide range of temperature and excellent resistance to many corrosives, in particular hydroxides. Nickel 200 can be hot formed to almost any shape. A temperature range of 650 to 1230°C is recommended and should be carefully adhered to because the proper temperature is the most important factor in achieving hot malleability. Full information of the forming process should be sought and understood before proceeding. 200 can be cold formed by all conventional methods, but because nickel alloys have greater stiffness than stainless steels more power is required to perform the operations. Other properties are

Good resistance to corrosion in acids and alkalies and is most useful under reducing conditions

Outstanding resistance to caustic alkalis up to and including the molten state

In acid, alkaline, and neutral salt solutions the material shows good resistance, but in oxidizing salt solutions severe attack will occur

Resistant to all dry gases at room temperature and in dry chlorine and hydrogen chloride may be used in temperatures up to 550°C

Resistance to mineral acids varies according to temperature and concentration and whether the solution is aerated or not; corrosion resistance is better in deaerated acid

Applications. It is used in the following:

Manufacture and handling of sodium hydroxide, particularly at temperature above 300°C

Production of viscose rayon and manufacture of soap

Aniline hydrochloride production and the chlorination of aliphatic hydrocarbons such as benzene, methane and ethane

Manufacture of vinyl chloride monomer

Storage and distribution systems for phenol; immunity from any form of attack ensures absolute product purity

Reactors and vessels in which fluorine is generated and reacted with hydrocarbons

Nitronic 60 (S21800)

Description and corrosion resistance. Nitronic 60 is truly an all-purpose metal. This fully austenitic alloy was originally designed as a high-temperature alloy for temperatures around 980°C. The oxidation resistance of Nitronic 60 is similar to S30900 steel and far superior to S30400 steel. The additions of silicon and manganese have given the alloy a matrix to inhibit wear, galling, and fretting even in the annealed condition. Higher strengths are attainable through cold working the material, and it is still fully austenitic after severe cold working. This working does not enhance the antigalling properties as is normal for carbon steels and some stainless steels. The cold or hot work put into the material adds strength and hardness.

The chromium and nickel additions give it comparable corrosion to S30400 and S31600 stainless steels, while having a twice the yield strengths of regular stainless steels. The high mechanical strength in annealed parts permits use of reduced cross sections for weight and cost reductions. Although uniform corrosion resistance of Nitronic 60 is better than S30400 stainless in most environments, its yield strength is nearly twice that of S30400 and S31600 steels. Chloride pitting resistance is superior to that of type S31600 stainless; Nitronic 60 provides excellent high-temperature oxidation resistance and low-temperature impact.

Nitronic 60 is also readily welded using conventional joining processes. It can be handled similarly to S30400 and S31600 steels. No preheat or postweld heat treatments are necessary, other than the normal stress relief used in heavy fabrication. Most applications use Nitronic 60 in the as-welded condition, unless corrosion resistance is a consideration. Fillerless fusion welds (autogenous) have been made using GTA. These welds are free from cracking and have galling and cavitation resistance similar to the unwelded base metal. Heavy weld deposits using this process are sound and exhibit higher strength than the unwelded base metal. The metal-to-metal wear resistance of the GMA welds are slightly lower than the base metal wear resistance.

Applications. Applications using Nitronic 60 are valve stems, seats and trim, fastening systems, screening, pins, bushings and roller bearings, pump shafts, and rings. Other uses include wear plates, rails guides, and bridge pins. This alloy provides a significant lower-cost way to fight wear and galling compared to nickel- or cobalt-based alloys. It is also used for

Automotive valves; it can withstand gas temperatures of up to 820°C for a minimum of 80,000 km

Fastener galling; it is capable of frequent assembly and disassembly, allowing more use of the fastener before the threads are torn up and also helps to eliminate corroded or frozen fasteners

Pins; it is used in roller prosthetics and chains to ensure a better fit of parts (closer tolerance, nonlubricated) and a longer life

Marine shafts; it has better corrosion than types 304 and 316, with double the yield strength

Pin and hanger expansion joints for bridges; it has better corrosion, galling resistance, low-temperature toughness, and high charpy values at subzero temperatures compared to the A36 and A588 carbon steels commonly used.